



SCALETRON™ SETS THE STANDARD
IN CORROSION RESISTANCE™

Model 2305™ Economical Digital Single Cylinder Scale

- Designed for weighing cylinders up to 12" in diameter
- Base size: 12-5/8" x 14-3/4"
- Net capacity: Up to 150 lbs. (68 or 70 kg)
- High accuracy of $\pm 0.25\%$ of capacity
- Single or multi-channel controllers with easy readability to 0.1 lb. (kg)
- Readout in pounds, kilograms, gallons or liters



AccuPro 5000-EK
Controller with
Encoder Knob

AccuPro 5000-PB
Controller with
3 Button Keypad

AccuPro 6000-TS
Controller with
Touch Screen

AccuPro 7000-TS
Controller with
Touch Screen



Economical Scale is Designed for Weighing Gas Cylinders

Model 2305 is designed for weighing gas cylinders up to 12" diameter. Featuring an economical single load cell design, the low-profile base and adjustable backstop allows for safe and easy handling and centering of cylinders. MADE IN USA.

Standard Features

- Rugged steel construction protected by a corrosion resistant, zinc oxide primed and dry powder epoxy coated finish, with solid 1/4" PVC decking for use in harsh environments
- Low profile platform (1.56") design increases safety and ease of cylinder handling
- Designed for centered loads – includes heavy-duty steel backstop with measuring guides to help position the cylinder
- Stainless steel, temperature compensated button load cell
- All hardware is stainless steel to prevent corrosion
- Mounting holes for securing base frame to floor
- Electronic indicator housed in NEMA 4X, UL approved enclosure to provide protection from acids
- 12 ft. of 4 conductor wire cable
- Cylinder support with tool rack and chains

Available Controllers

- AccuPro 5000-EK/PB™ with one or 2 channels, encoder knob or 3 button keypad, audible alarm and 4-20 mA output – scale or loop powered
- AccuPro 6000™ with one or 2 channels or AccuPro 7000™ with up to 4 channels, touch screen, optional audible alarm and 4-20 mA outputs – scale powered

Options

- High and low level set points
- 0-5V or 0-10V output signal
- Remote mounting of indicator box up to 200 feet away

Chemicals

- Scale is designed to accurately measure weight of ammonia, carbon dioxide, hydrogen chloride, liquefied chlorine, sulfur dioxide and other liquid gases

Model 2305™ Economical Digital Single Cylinder Scale Specifications

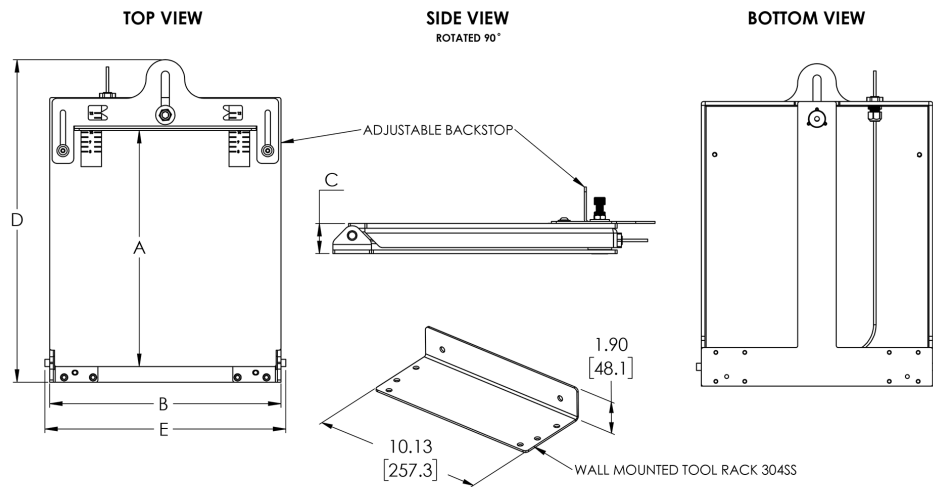

Scale Base

PART NUMBER	2305
Platform Length (A)	12.24" (311 mm)
Platform Width (B)	12.0" (309 mm)
C	1.56" (40 mm)
D	16.72" (425 mm)
E	12.5" (318 mm)
Gross Capacity	Up to 150 lbs. (68 or 70 kg)
Weight	23 lbs.

Digital Controllers

PART NUMBER	ACCUPRO 5000-EK or PB	ACCUPRO 6000-TS	ACCUPRO 7000-TS
Interface	Encoder knob or 3 button keypad	Touch screen	Touch screen
Accuracy	±0.1% to ±0.25% of full scale capacity	±0.1% to ±0.25% of full scale capacity	±0.1% to 0.25% of full scale capacity
Display	2 Line x 16 character alphanumeric backlit LCD with 6 digits for weight	4.3" Graphic color touch screen display with adjustable brightness	4.3" Graphic color LCD touch screen display with adjustable brightness
Display Items	Net weight plus bar graph with net weight, gross weight and tare adjustment	Net and gross weight, % and bar graphs plus mA out, tare adjustment and set point values	Net and gross weight, % and bar graphs; mA out, tare adj., set points; data log, feed rate, daily usage, amount used, days till empty; batch net wt, batch and total amount, time
Channels	1 or 2 - One scale base per channel	1 or 2 - One scale base per channel	Up to 4 - One scale base per channel
Output Signal	4-20mA Standard, 0-5V or 0-10V optional - scale or loop powered	4-20mA Standard - scale powered	4-20mA Optional - scale powered
Set Points	2 or 4 Per channel (high or low)	2 or 4 Per channel (high or low)	2 or 4 Per channel (high or low) - max. 8
Remote Option	Up to 200 feet from base frame	Up to 200 feet from base frame	Up to 200 feet from base frame
Audible Alarm	78 dB Internal piezo buzzer, adjustable volume, external buzzer support	Optional 78 dB internal piezo buzzer, external buzzer support	Optional 78 dB internal piezo buzzer, external buzzer support
Communication Option		Modbus TCP or RTU	Modbus TCP or RTU
Power	90/240 VAC, 50/60Hz, 0.10/00.5A	100/277 VAC, 50/60 Hz, 0.10/0.05A	100/277 VAC, 50/60 Hz, 0.10/0.05A
Weight	NEMA 4X, UL approved enclosure	NEMA 4X, UL approved enclosure	NEMA 4X, UL approved enclosure
Enclosure	7lbs.	7lbs.	7lbs.

Scaleton Industries Ltd.

Bedminster Industrial Park
53 Apple Tree Lane • P.O. Box 365
Plumsteadville, PA 18949 • USA

Tel: (+1) 215-766-2670 (International)
Tel: (+1) 800-257-5911 (USA & Canada)
Fax: (+1) 215-766-2672

Email: info@scaletonscales.com
Website: www.scaletonscales.com