

## Model 2350™ Digital Dual Cylinder Scale

- Designed for weighing cylinders up to 12" in diameter
- Two independent weighing disks
- Base size: 32" x 18"
- Net capacity: Up to 150 lbs. (68 or 70 kg) per disk
- High accuracy of  $\pm 0.1\%$  of capacity
- AccuPro 5000 dual channel controller with easy readability to 0.1 lb. (kg)
- Readout in pounds, kilograms, gallons or liters
- Patented



## The Ideal Weighing Solution for Applications Requiring Frequent On/Off Loading of Gas Cylinders

Model 2350 is designed for weighing two gas cylinders up to 12" in diameter. Featuring a three-point suspension on the weighing disks, the low-profile base allows for safe and easy handling of cylinders. MADE IN USA.

### Standard Features

- Rugged steel construction protected by a corrosion resistant, zinc oxide primed and dry powder coated finish, with molded fiberglass reinforced thermoplastic base and weighing disks for use in harsh environments
- Low profile platform design (1-1/2") increases safety and ease of cylinder handling
- Six (6) stainless steel bending beam, temperature compensated load cells
- All hardware is stainless steel to prevent corrosion
- Electronic indicator housed in NEMA 4X, UL approved enclosure to provide protection from acids
- Cylinder support and chains

### Available Controllers

- AccuPro 5000-EK/PB™ with one or 2 channels, encoder knob or 3 button keypad, audible alarm and 4-20 mA output – scale or loop powered
- AccuPro 6000™ with one or 2 channels, touch screen, optional audible alarm and 4-20 mA outputs – scale powered

### Options

- High and low level set points
- 0-5V or 0-10V output signal
- Remote mounting of indicator box up to 200 feet away

### Chemicals

- Scale is designed to accurately measure weight of ammonia, carbon dioxide, hydrogen chloride, liquefied chlorine, sulfur dioxide and other liquid gases

# Model 2350™ Digital Dual Cylinder Scale Specifications

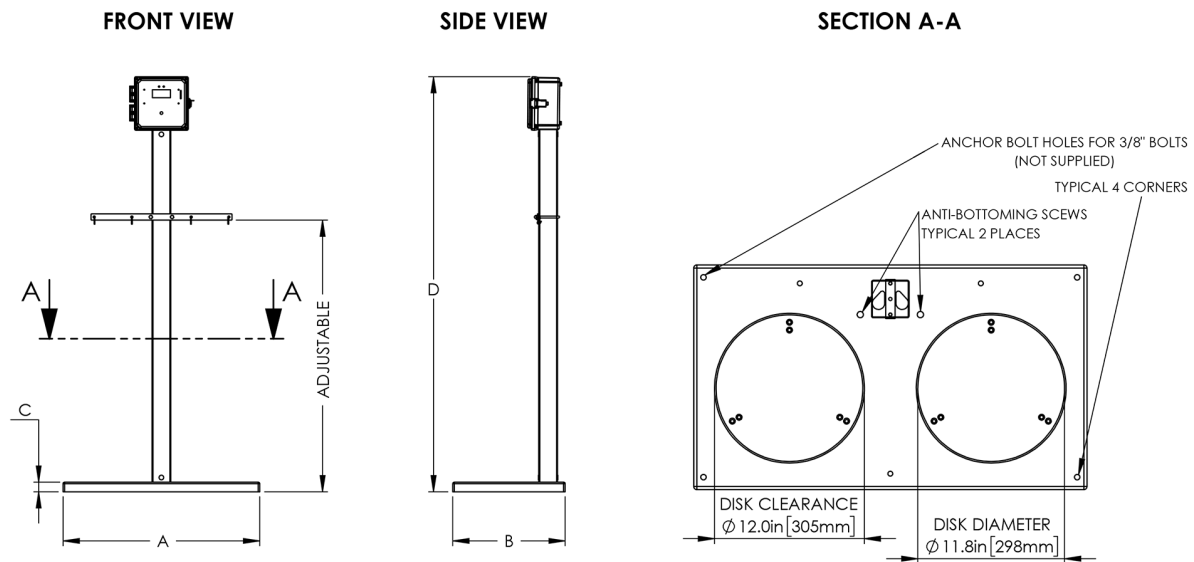

## Scale Base

PART NUMBER	2350
Platform Length (A)	31.5" (800 mm)
Platform Width (B)	18.0" (457 mm)
Platform Height (C)	1.50" (38 mm)
D	66.5" (1690 mm)
Net Capacity	Up to 150 lbs. (68 or 70 kg) per disk
Weight	27 lbs. scale; 15 lbs. post

## Digital Controllers

PART NUMBER	ACCUPRO 5000-EK or PB	ACCUPRO 6000-TS
Interface	Encoder knob or 3 button keypad	Touch screen
Accuracy	±0.1% to ±0.25% of full scale capacity	±0.1% to ±0.25% of full scale capacity
Display	2 Line x 16 character alphanumeric backlit LCD with 6 digits for weight	4.3" Graphic color touch screen display with adjustable brightness
Display Items	Net weight plus bar graph with net weight, gross weight and tare adjustment	Net and gross weight, % and bar graphs plus mA out, tare adjustment and set point values
Channels	1 or 2 - One scale base per channel	1 or 2 - One scale base per channel
Output Signal	4-20mA Standard, 0-5V or 0-10V optional - scale or loop powered	4-20mA Standard - scale powered
Set Points	2 or 4 Per channel (high or low)	2 or 4 Per channel (high or low)
Remote Option	Up to 200 feet from base frame	Up to 200 feet from base frame
Audible Alarm	78 dB Internal piezo buzzer, adjustable volume, external buzzer support	Optional 78 dB internal piezo buzzer, external buzzer support
Communication Option		Modbus TCP or RTU
Power	90/240 VAC, 50/60Hz, 0.10/00.5A	100/277 VAC, 50/60 Hz, 0.10/0.05A
Weight	NEMA 4X, UL approved enclosure	NEMA 4X, UL approved enclosure
Enclosure	7lbs.	7lbs.

### Scaleton Industries Ltd.

Bedminster Industrial Park  
53 Apple Tree Lane • P.O. Box 365  
Plumsteadville, PA 18949 • USA

Tel: (+1) 215-766-2670 (International)  
Tel: (+1) 800-257-5911 (USA & Canada)  
Fax: (+1) 215-766-2672

Email: [info@scaletonscales.com](mailto:info@scaletonscales.com)  
Website: [www.scaletonscales.com](http://www.scaletonscales.com)