

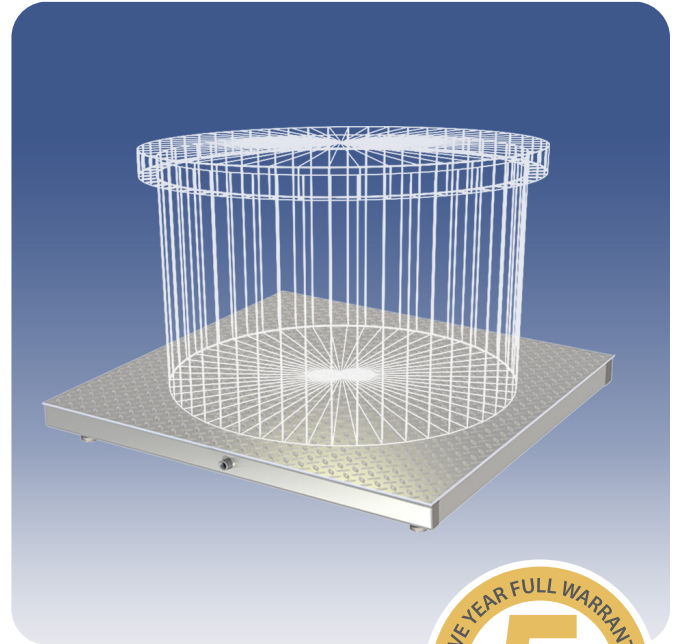

SCALETRON™ SETS THE STANDARD
IN CORROSION RESISTANCE™

Model 4040SS™ Stainless Steel Digital Platform Scale

- **Standard base sizes:** 24" x 24", 30" x 30", 36" x 36", 48" x 48", 60" x 60", 72" x 72" – custom sizes available
- **Net capacity:** Up to 10,000 lbs. (4535 kg) – custom capacities available
- **High accuracy of ±0.1% of capacity**
- **Single or multi-channel controllers with easy readability to 0.1 lb. (kg)**
- **Readout in pounds, kilograms, gallons or liters**



AccuPro 5000-EK
Controller with
Encoder Knob

AccuPro 5000-PB
Controller with
3 Button Keypad

AccuPro 6000-TS
Controller with
Touch Screen

AccuPro 7000-TS
Controller with
Touch Screen

High Capacity Weighing Solution for Highly Corrosive Chemicals with Frequent On/Off Loading of Drums and Tanks

The Model 4040 is designed for weighing tank, drums and totes up to 72"x72". Featuring a four (4) load cell design, the scale base is ideal for high capacity applications requiring frequent on/off loading of containers. MADE IN USA.

Standard Features

- Rugged, corrosion resistant 304 or 316 stainless steel construction, with stainless steel diamond plate deck for use in harsh environments
- Low profile platform (3.75" to 5.44") design increases safety and ease of container handling
- Accommodates off-center loads – containers can be placed anywhere on the scale platform and do not need to be leveled
- Four (4) NTEP stainless steel shear beam, temperature compensated load cells
- All hardware is stainless steel to prevent corrosion
- Electronic indicator housed in NEMA 4X, UL approved enclosure to provide protection from acids
- 20 ft. of 4 conductor wire cable

Available Controllers

- AccuPro 5000-EK/PB™ with one or 2 channels, encoder knob or 3 button keypad, audible alarm and 4-20 mA output – scale or loop powered
- AccuPro 6000™ with one or 2 channels or AccuPro 7000™ with up to 4 channels, touch screen, optional audible alarm and 4-20 mA outputs – scale powered

Options

- High and low level set points
- 0-5V or 0-10V output signal
- Remote mounting of indicator box up to 200 feet away
- Seismic hold down brackets
- Stainless steel, ball-bearing bolt down feet (4)

Chemicals

- Scale is designed to accurately measure weight of alum, ammonia, caustic, fluoride, phosphate, polymers, sodium aluminate, sodium bisulfate, sodium hydroxide, sodium hypochlorite and other liquids or powders

Model 4040SS™ Stainless Steel Digital Platform Scale Sizes & Specifications

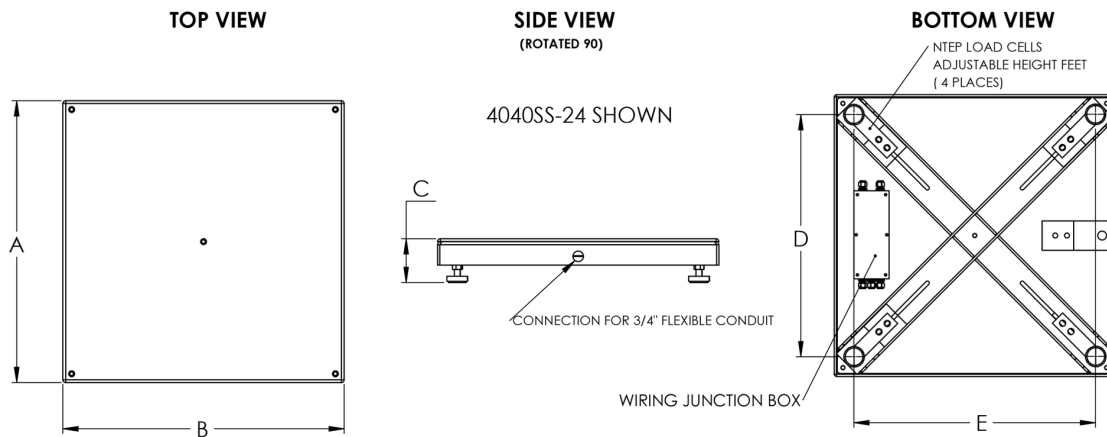

Scale Base

PART NUMBER	4040SS-24	4040SS-30	4040SS-36	4040SS-48	4040SS-60	4040SS-72
Platform Length (A)	24" (610 mm)	30" (762 mm)	36" (914 mm)	48" (1219 mm)	60" (1524 mm)	72" (1828.8 mm)
Platform Width (B)	24" (610 mm)	30" (762 mm)	36" (914 mm)	48" (1219 mm)	60" (1524 mm)	72" (1828.8 mm)
Platform Height (C)	3.75" (95 mm) - add 1/2" for bolt down feet	3.75" (95 mm) - add 1/2" for bolt down feet	3.75" (95 mm) - add 1/2" for bolt down feet	4.75" (121 mm) - add 1/2" for bolt down feet	4.75" (121 mm) - add 1/2" for bolt down feet	5.44" (138 mm) - add 1/2" for bolt down feet
D	19.78" (503 mm)	26.37" (670 mm)	31.82" (808 mm)	44.62" (1133 mm)	58" (1473 mm)	65" (1651 mm)
E	20.75" (527 mm)	27.05" (687 mm)	36.42" (925 mm)	45.17" (1147 mm)	58" (1473 mm)	65.75" (1670 mm)
Net Capacity	Up to 1000 lbs. (454 kg) (150% overload protection)	Up to 1000 lbs. (454 kg) (150% overload protection)	Up to 2500 lbs. (1134 kg) (150% overload protection)	Up to 5000 lbs. (2268 kg) (150% overload protection)	Up to 8000 lbs. (3629 kg) (150% overload protection)	Up to 10,000 lbs. (4536 kg) (150% overload protection)
Weight	130 lbs.	150 lbs.	160 lbs.	240 lbs.	370 lbs.	545 lbs.

Digital Controllers

PART NUMBER	ACCUPRO 5000-EK or PB	ACCUPRO 6000-TS	ACCUPRO 7000-TS
Interface	Encoder knob or 3 button keypad	Touch screen	Touch screen
Accuracy	±0.1% to ±0.25% of full scale capacity	±0.1% to ±0.25% of full scale capacity	±0.1% to 0.25% of full scale capacity
Display	2 Line x 16 character alphanumeric backlit LCD with 6 digits for weight	4.3" Graphic color touch screen display with adjustable brightness	4.3" Graphic color LCD touch screen display with adjustable brightness
Display Items	Net weight plus bar graph with net weight, gross weight and tare adjustment	Net and gross weight, % and bar graphs plus mA out, tare adjustment and set point values	Net and gross weight, % and bar graphs; mA out, tare adj., set points; data log, feed rate, daily usage, amount used, days till empty; batch net wt, batch and total amount, time
Channels	1 or 2 - One scale base per channel	1 or 2 - One scale base per channel	Up to 4 - One scale base per channel
Output Signal	4-20mA Standard, 0-5V or 0-10V optional - scale or loop powered	4-20mA Standard - scale powered	4-20mA Optional - scale powered
Set Points	2 or 4 Per channel (high or low)	2 or 4 Per channel (high or low)	2 or 4 Per channel (high or low) - max. 8
Remote Option	Up to 200 feet from base frame	Up to 200 feet from base frame	Up to 200 feet from base frame
Audible Alarm	78 dB Internal piezo buzzer, adjustable volume, external buzzer support	Optional 78 dB internal piezo buzzer, external buzzer support	Optional 78 dB internal piezo buzzer, external buzzer support
Communication Option		Modbus TCP or RTU	Modbus TCP or RTU
Power	90/240 VAC, 50/60Hz, 0.10/0.05A	100/277 VAC, 50/60 Hz, 0.10/0.05A	100/277 VAC, 50/60 Hz, 0.10/0.05A
Weight	NEMA 4X, UL approved enclosure	NEMA 4X, UL approved enclosure	NEMA 4X, UL approved enclosure
Enclosure	7lbs.	7lbs.	7lbs.

Scaleton Industries Ltd.

Bedminster Industrial Park
53 Apple Tree Lane • P.O. Box 365
Plumsteadville, PA 18949 • USA

Tel: (+1) 215-766-2670 (International)
Tel: (+1) 800-257-5911 (USA & Canada)
Fax: (+1) 215-766-2672

Email: info@scaletonscales.com
Website: www.scaletonscales.com