



SCALETRON™ SETS THE STANDARD
IN CORROSION RESISTANCE™

Model 4042ECO-26™ Economical Spill Containment Drum Scale

- Splashes and spills of hazardous chemicals are captured within the containment basin
- Standard base size: 26" x 24" – other sizes available
- Net capacity: Up to 1,000 lbs. (454 kg) – other capacities available
- Containment capacity: 11 gal.
- High accuracy of $\pm 0.25\%$
- Single or multi-channel controllers with easy readability to 0.1 lb. (kg)
- Readout in pounds, kilograms, gallons or liters



AccuPro 5000-EK
Controller with
Encoder Knob

AccuPro 5000-PB
Controller with
3 Button Keypad

AccuPro 6000-TS
Controller with
Touch Screen

AccuPro 7000-TS
Controller with
Touch Screen



Economical Drum Scale Meets EPA & OSHA Requirements for Spill Containment

Model 4042ECO-26 is designed for weighing tanks and drums up to 26" in diameter. Featuring an economical single load cell design, the scale base is ideal for centered load, pump in/out applications. MADE IN USA.

Standard Features

- Rugged steel construction protected by corrosion resistant, zinc oxide primed and dry powder epoxy coated finish, with polyethylene containment basin for use in harsh environments
- Designed for centered loads – includes heavy-duty steel backstop to help position the drum
- Hinged base can be lifted for easy access and cleaning of the basin
- NTEP stainless steel shear beam, temperature compensated load cells with stainless steel leveling foot
- Load cell is mounted outside of spill containment basin to eliminate damage due to chemical spills
- All hardware is stainless steel to prevent corrosion
- Electronic indicator housed in NEMA 4X, UL approved enclosure to provide protection from acids
- 20 ft. of 4 conductor wire cable

Available Controllers

- AccuPro 5000-EK/PB™ with one or 2 channels, encoder knob or 3 button keypad, audible alarm and 4-20 mA output – scale or loop powered
- AccuPro 6000™ with one or 2 channels or AccuPro 7000™ with up to 4 channels, touch screen, optional audible alarm and 4-20 mA outputs – scale powered

Options

- High and low level set points
- 0-5V or 0-10V output signal
- Remote mounting of indicator box up to 200 feet away

Chemicals

- Scale is designed to accurately measure weight of alum, ammonia, caustic, fluoride, phosphate, polymers, sodium aluminate, sodium bisulfate, sodium hydroxide, sodium hypochlorite and other liquids or powders

Model 4042ECO-26™ Economical Spill Containment Drum Scale Specifications

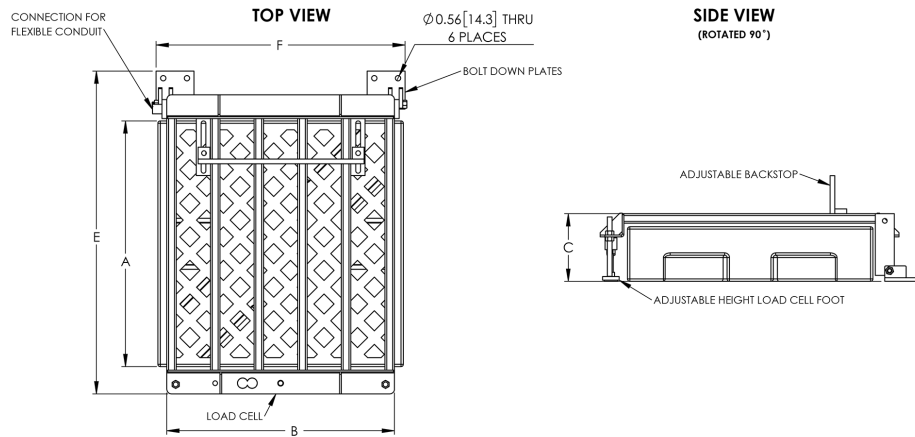

Scale Base

PART NUMBER	4042ECO
Platform Length (A)	25.88" (657 mm)
Platform Width (B)	24.00" (610 mm)
Platform Height (C)	7.0" (178 mm)
E	34.00" (834 mm)
F	26.25" (667 mm)
Net Capacity	Up to 1000 lbs. (454 kg) (150% overload protection is provided)
Containment Capacity	11 gal.
Weight	96 lbs.

Digital Controllers

PART NUMBER	ACCUPRO 5000-EK or PB	ACCUPRO 6000-TS	ACCUPRO 7000-TS
Interface	Encoder knob or 3 button keypad	Touch screen	Touch screen
Accuracy	±0.1% to ±0.25% of full scale capacity	±0.1% to ±0.25% of full scale capacity	±0.1% to 0.25% of full scale capacity
Display	2 Line x 16 character alphanumeric backlit LCD with 6 digits for weight	4.3" Graphic color touch screen display with adjustable brightness	4.3" Graphic color LCD touch screen display with adjustable brightness
Display Items	Net weight plus bar graph with net weight, gross weight and tare adjustment	Net and gross weight, % and bar graphs plus mA out, tare adjustment and set point values	Net and gross weight, % and bar graphs; mA out, tare adj., set points; data log, feed rate, daily usage, amount used, days till empty; batch net wt, batch and total amount, time
Channels	1 or 2 - One scale base per channel	1 or 2 - One scale base per channel	Up to 4 - One scale base per channel
Output Signal	4-20mA Standard, 0-5V or 0-10V optional - scale or loop powered	4-20mA Standard - scale powered	4-20mA Optional - scale powered
Set Points	2 or 4 Per channel (high or low)	2 or 4 Per channel (high or low)	2 or 4 Per channel (high or low) - max. 8
Remote Option	Up to 200 feet from base frame	Up to 200 feet from base frame	Up to 200 feet from base frame
Audible Alarm	78 dB Internal piezo buzzer, adjustable volume, external buzzer support	Optional 78 dB internal piezo buzzer, external buzzer support	Optional 78 dB internal piezo buzzer, external buzzer support
Communication Option		Modbus TCP or RTU	Modbus TCP or RTU
Power	90/240 VAC, 50/60Hz, 0.10/00.5A	100/277 VAC, 50/60 Hz, 0.10/0.05A	100/277 VAC, 50/60 Hz, 0.10/0.05A
Weight	NEMA 4X, UL approved enclosure	NEMA 4X, UL approved enclosure	NEMA 4X, UL approved enclosure
Enclosure	7lbs.	7lbs.	7lbs.

Scaleton Industries Ltd.

Bedminster Industrial Park
53 Apple Tree Lane • P.O. Box 365
Plumsteadville, PA 18949 • USA

Tel: (+1) 215-766-2670 (International)
Tel: (+1) 800-257-5911 (USA & Canada)
Fax: (+1) 215-766-2672

Email: info@scaletonscales.com
Website: www.scaletonscales.com