

COMPONENT LISTING

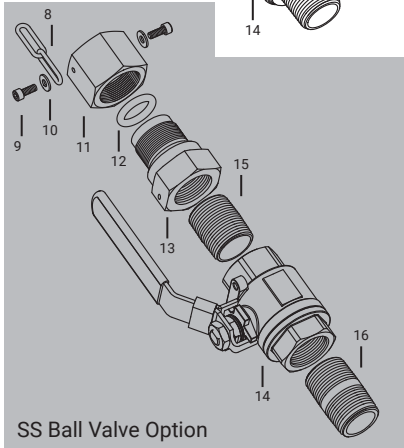
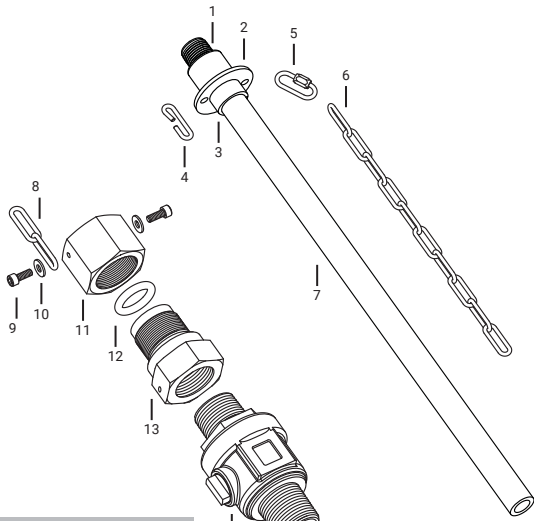

SS Ball Valve Option

ID	Name	ID	Name
Solution Tube Assembly		Main Connection Assembly	
1	Inlet Thread	8	Restraint Chain
2	Chain Plate	9	Restraint Screw (x2)
3	Collar	10	Washer (x2)
4	Restraint Hook	11	Packing Nut
5	Threaded Connector	12	Compression O-ring
6	Limit Chain	13	Solution Tube Adapter
7	Solution Tube	14	Isolation Valve
		15	Upper Nipple*
		16	Lower Nipple*

*Stainless steel ball valve equipped quills.



INSTALLATION AND OPERATION MANUAL

Standard Service Retractable
Injection Quills
EB-130, EB-132, EB-191, EB-159, EB-160

WARRANTY

All merchandise is warranted to be free from defects in material and factory workmanship. We will provide free of charge new products in equal quantities for any that prove defective within one year from date of shipment from our factory. Manufacturer shall not be liable for any loss, damage, or injury, direct or consequential, arising out of the use of or the inability to use the product. Before using, user shall determine the suitability of the product for its intended use and user assumes all risk and liability whatever in connection therewith. No claims for labor or consequential damage will be allowed. The foregoing may not be changed except by agreement signed by an officer of the manufacturer.

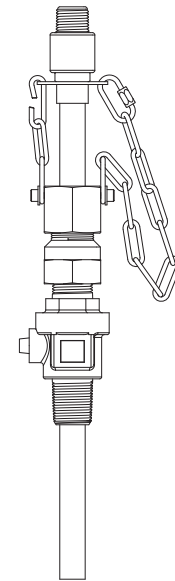

SAF-T-FLO Chemical Injection
4091-U East La Palma Avenue
Anaheim, CA 92807
714-632-3013 | www.saftflo.com

INSTALLATION

BEFORE INSTALLING

- Quills are shipped in their operating configuration. Installation may require that the solution tube be removed.
- Hot tapping is not recommended. If planning on hot tapping, please refer to the technical references available at www.saftflo.com or contact SAF-T-FLO technical assistance.
- It is recommended that you do not disassemble the packing gland for installation of the quill. The threads of the gland will not be protected and may become damaged. Such damage is not covered under warranty.
- If the quill does not include the optional check valve, precaution must be taken to ensure that there is some means of isolation in place prior to exposing the solution tube to the process pressure.

INSTALLING WITH SOLUTION TUBE INSERTED

1. Apply suitable thread sealant to the process connection thread.
2. Install the quill onto the process line by threading the main connection valve to the tap on the process line.
3. Connect the chemical feed line to the inlet of the quill.

INSTALLING WITH SOLUTION TUBE REMOVED

1. With the valve in the closed position. Apply suitable thread sealant to the process connection thread.
2. Install the main connection valve onto the tap of the process line.
3. Insert the solution tube following the solution tube insertion instructions in this manual.
4. Connect the chemical feed to the inlet of the quill.

AFTER INSTALLING / PRIOR TO OPERATING

1. Inspect the restraint system to ensure that it is properly in place and ready for operation. Check to verify that:
 - a. Restraint and limit chains are connected to the packing nut using the supplied screws and washers.
 - b. Restraint chain is hooked off onto the restraint hook and both chain and hook are fully extended.
 - c. Limit chain is connected the threaded connector and the jaw of the connector is closed.
2. Ensure all connections have been made prior to pressurizing.

OPERATION

PRECAUTIONS

- Process pressure should be reduced as much as possible prior to inserting or retracting the solution tube.
- Inspect restraint hardware to ensure it is in proper condition.
- Do not stand directly in line with the quill when operating.
- Take all necessary precautions to protect against possible chemical exposure when working with the quill.
- Do not use a wrench to tighten the packing nut. Hand tighten only.

INSERTING THE SOLUTION TUBE

1. Inspect restraint hardware to ensure it is suitable for use.
2. Insert the solution tube into the valve assembly until the tip seats against the ball of the closed isolation valve.
3. Lock off the limit chain to the threaded connector and close the jaw. Chain should be extended with no kinks and minimal slack.
4. Hand tighten packing nut until resistance is felt.
5. Before continuing, ensure that there is a point of isolation installed at the inlet of the quill (ex. check valve, ball valve, feed piping).
6. Slowly open the isolation valve. Allow the limit chain to take up the pressure. Tighten packing nut to seal against any leaks.
7. Once the valve is fully open, slide the solution tube through the valve assembly until the restraint chain can be secured to the restraint hook. The hook and chain should be taut- restraining the solution tube.
8. Connect the chemical feed to the inlet of the quill.

RETRACTING THE SOLUTION TUBE

1. Shutdown and isolate the chemical feed from the quill. Detach feed piping as needed to ensure the quill can retract unobstructed.
2. Maintain a firm grasp on the solution tube and push down into the valve assembly to remove tension from the restraint hook/chain.
3. Disconnect restraint chain from hook and slowly back out the tube until the limit chain is fully extended.
4. With the limit chain fully extended. Close the valve, isolating from the process pressure.
5. Slowly back off the packing nut to bleed off any residual pressure.
6. With the quill isolated from the process pressure and residual pressure bled off, detach the limit chain from the threaded connector.
7. Remove the tube from the valve assembly.

MAINTENANCE

VISUAL INSPECTION

Periodic visual inspections should be done to examine the overall integrity of the quill and to verify that no leaks (chemical or process side) have developed.

SOLUTION TUBE MAINTENANCE

Solution tubes may clog due to deposit formation. The rate and severity will depend on the chemistry of the application. After the quill is put into operation it should be periodically retracted to determine the rate at which the deposit formation is occurring. Maintenance cycles can then be based on observations.

Deposits can typically be removed by soaking the tube in warm water and then brushing the deposits off. In other cases a weak acid solution may be utilized.

REPLACEMENT PARTS

The following sub-assemblies and kits are available for replacement:

- Solution Tube Assembly
- Main Connection Valve Assembly
- Check Valve Repair Kits

NEED ASSISTANCE?

CUSTOMER SERVICE

800-957-2383

M-F (7am - 4pm Pacific)

INSTRUCTIONAL VIDEOS

<https://saftflo.com/videos>