



 chlorinators incorporated

1044 SE Dixie Cutoff Road, Stuart, Florida 34994 USA

Phone: (772) 288-4854 Fax: (772) 287-3238

www.regalchlorinators.com Email: regal@regalchlorinators.com

REGAL Ejector Check Valve Assemblies

INSTALLATION/SERVICE MANUAL

INTRODUCTION

These instructions provide installation and service procedures for all REGAL Chlorinator ejectors to 2,000 PPD, all REGAL Sulphonator ejectors to 500 PPD, and all REGAL Ammoniator ejectors to 100 PPD. The typical installation drawings used in this Instruction Bulletin are meant as a guide only. They are general in nature and may not depict the specific REGAL ejector furnished with your system.

All REGAL ejectors contain one or two check valve devices to prevent water from backing up into the various chlorinator or sulphonator system components (FLOODING) when ejector vacuum is lost due to normal

(or non-normal) system shut down. To assure flooding does not occur under these circumstances, routine maintenance of the check valve(s) is necessary. The frequency of needed servicing depends on the cleanliness of the water used to operate the ejector, the cleanliness of the chemical source and therefore the internal cleanliness of the chlorinator system components, the frequency of ejector cycling (ON/OFF), and the pressures the ejector operates against.

It is your (the customer's) responsibility to establish and undertake a SCHEDULED MAINTENANCE PROGRAM. SEE SECTION 5.0 IN THIS MANUAL.

IMPORTANT NOTES

1. The entire contents of this manual MUST be read and understood prior to installing and operating this equipment.
2. DO NOT discard this instruction manual upon completion of the installation as this manual contains information essential to the safe handling, operation, and maintenance of this equipment.
3. Additional instruction manuals are available at nominal cost from Chlorinators Incorporated.
4. Plastic pipe or tubing connector fittings may be broken or damaged if tightened excessively. HAND TIGHTEN ONLY.

WARNINGS

1. Before working on any chlorinator system component, CLOSE ALL CYLINDER, CONTAINER, OR MANIFOLD VALVES.
2. This equipment is suitable for use only with the gases specified. DO NOT USE THIS EQUIPMENT WITH OTHER GASES. Such use can result in failures having hazardous consequences.
3. THIS EQUIPMENT IS DESIGNED FOR VACUUM SERVICE ONLY.
4. To insure proper and safe operation of this equipment, use only REGAL parts. The use of non-REGAL parts can result in equipment failures having hazardous consequences and voids the REGAL warranty and insurance coverage.
5. Maintenance should be performed by competent personnel familiar with this type of equipment, such as Chlorinators Incorporated themselves.
6. Piping to and from the ejector should never be smaller than the ejector inlet and outlet sizes.
7. For optimum ejector performance, friction losses in the ejector supply and solution lines (including valves and fittings) should be kept to a maximum of 5' per 100' of pipe length.

CHLORINATORS INCORPORATED ONE (1) YEAR LIMITED WARRANTY

Chlorinators Incorporated (hereinafter called "C.I.") sets forth the following warranties with respect to its REGAL Gas Chlorinators, Gas Sulphonators, Gas Ammoniators, System Components and Sub-Assemblies. This warranty does not apply to the purchase of spare parts or other services performed by C.I. This represents the entire agreement between C.I. and Buyer (also referred to as "end-user") and shall apply unless modified in writing and signed by a C.I. officer, and this warranty and its intended terms shall supersede any prior negotiations, correspondence, understandings, or agreements, written or oral. The Buyer agrees to and accepts all terms of this warranty by its contracting for or acceptance of C.I.'s products, and forms or other documents or statements issued by Buyer or any other person shall not modify or otherwise affect any of the following terms. Buyer should be aware that reseller must rely entirely upon Chlorinators Incorporated's warranties, or assume their own responsibility.

The following states C.I.'s entire warranty and represents Buyer's exclusive remedy with respect to its product. Such warranties are expressly given in lieu of any other warranty, expressed or implied, including but not limited to those of merchantability and fitness for a particular purpose. This expressed warranty or any other warranty implied by law shall not cover defects due to accident, improper use, or non-compliance with C.I.'s operating and maintenance, assembly, installation manual and instructions.

Recommendations and advice as to specifications, capabilities, design, installation, engineering, application, and use of products are provided as an accommodation, and are intended only as suggestions. C.I. assumes no liability for such recommendations and advice, and they are not to be construed as constituting any warranty, expressed or implied.

TERMS OF WARRANTY

C.I. warrants its REGAL Gas Chlorinators, Gas Sulphonators, Gas Ammoniators, System Components and Sub-Assemblies for a period of one (1) year from date of shipment from C.I. Date of shipment from the factory shall be determined solely on the basis of the chlorinator serial code stamped on the vacuum regulator back body. The serial number contains a date code. All serial numbers are also registered by Chlorinators Incorporated as to date of shipment, model number, chlorine feed rate capacity, and billing name. If the serial number is missing, defaced, changed, or in any way rendered unreadable, Chlorinators Incorporated shall, at its option, have the right to declare the warranty void. If the serial number does not match the registered model number as to, but not limited to, such items as maximum chlorine feed rate, the same option shall be applicable.

The warranty shall apply against material defects in components, and workmanship occurring in the course of manufacture. Buyer's sole remedy for breach of said warranty shall be, at C.I.'s option, either repair or replacement of any unit which is received by C.I. at its plant in Stuart, Florida, (shipping charges prepaid by buyer) within the time period set forth above and which is found by C.I. to be defective by reason of manufacture.

Notwithstanding the foregoing, C.I. shall not be liable to Buyer for damages, including personal injury or death to any person or persons, or claims of any kind by a third party or property damage, loss of business or profits. In no event shall C.I. be liable to Buyer for consequential or accidental damages of any kind, even if C.I. was aware of the possibility of such damages. There are no remedies except those set forth. Further, that there are no other authorized warranty repair facilities other than those at the Chlorinators Incorporated factory in Stuart, Florida.

EXCLUSIONS

The following are considered external environmental factors beyond the control of C.I., and which may cause damage and/or need for service which will be specifically excluded from this warranty (i.e., not a material defect in components and workmanship occurring in the course of manufacture).

1. Impurities from gas supplies introduced onto sealing and metering surfaces or into any passageways.
2. "Flooding" of unit due to impurities and/or precipitants on ejector check valve sealing surfaces.
3. Introduction of liquified gas into the unit.
4. Physical damage due to force, dropping, or other abuse.
5. Use with a material for which the unit is not specifically designed.
6. Use in an application beyond the rated feed rate capacity or pressures of the unit.
7. Any alteration of design, or use of non-C.I. manufactured parts.

The exclusions listed above are provided for purposes of clarification, and are not intended to, in any way, limit or eliminate other possible exclusions.

NO OTHER WARRANTIES

Unless otherwise explicitly agreed in writing, and signed by a C.I. officer, it is understood that this is the only written warranty given by C.I. for the systems and components stated.

The dealers or representatives of C.I. may not make verbal representations that add, modify or change the written warranties contained herein or change the extent and nature of C.I.'s liability. In no event shall C.I. be liable for direct, consequential, special, incidental or punitive, damages of any kind with respect to the product, including but not limited to those which may allegedly arise out of breach of warranty, breach of contract, negligence, strict liability, or any other law, governmental regulation, or court decision, except as provided herein.

CONTENTS

1.0 INSTALLATION OF EJECTORS TO 500 PPD.

2.0 INSTALLATION OF EJECTORS @ 1000/2000 PPD.

3.0 PIPING OF EJECTOR

4.0 START-UP

5.0 SERVICE / DISASSEMBLY

- 5.1 High Pressure Ejectors To 500 PPD.
- 5.2 **OPTIONAL** Low Pressure Ejectors To 500 PPD.
- 5.3 **OPTIONAL** A-927 High/Low Ejector To 100 PPD.
- 5.4 **OPTIONAL** A-950 Dual Check Valve Ejector To 500 PPD.
- 5.5 A-2920/A-2922 1000/2000 PPD Ejectors.
- 5.6 Cleaning/Inspection Of Ejector Nozzles To 500 PPD.
- 5.7 Cleaning/Inspection Of Ejector Nozzles @ 1000/2000 PPD.

6.0 SECONDARY CHECK VALVES FOR 500 PPD AND BELOW EJECTORS

DRAWING, PHOTO AND BULLETIN INDEX

Photos No. 1 through No. 11	500 PPD And Below Ejector Photos
Photos No. 12 through No. 13	Secondary Check Valves To 500 PPD
Drawing No. 1	Typical 500 PPD And Below Ejector Installations
Drawing No. 2	Typical 100 PPD And Below Ejector Inlet and Outlet Connections
Drawing No. 3	Typical Installation Drawing Of Remote Mounted Ejector With Solution Line To Point Of Chemical Application
Drawing A-920/A-922/A-925	Parts List Drawing For HIGH PRESSURE Ejectors To 500 PPD CHLORINE SERVICE ONLY
Drawing A-920S/A-922S/A-925S	Parts List Drawing For HIGH PRESSURE Ejectors To 500 PPD SULFUR DIOXIDE SERVICE ONLY
Drawing No. A-927/A-927A A-301/A-301A	OPTIONAL Chlorine/Ammonia Service Ejector Assembly (High/Low Pressure) OPTIONAL Chlorine/Ammonia Service Check Valve Assembly (High/Low Pressure)
Drawing A-920A	Parts List Drawing For HIGH PRESSURE Ejector To 100 PPD AMMONIA SERVICE ONLY
Drawing A-921/A-923/A-926	OPTIONAL Parts List Drawing For LOW PRESSURE Ejectors To 500 PPD CHLORINE SERVICE ONLY
Drawing A-921S/A-923S/A-926S	OPTIONAL Parts List Drawing For LOW PRESSURE Ejectors To 500 PPD SULFUR DIOXIDE SERVICE ONLY
Drawing A-921A	OPTIONAL Parts Drawing List For LOW PRESSURE Ejector To 100 PPD AMMONIA SERVICE ONLY
Drawing A-930	OPTIONAL HIGH/LOW PRESSURE Ejector Assembly
Drawing A-950/A-949	OPTIONAL Dual Check Valve Ejector to 500 PPD
Drawing A-2920/A-2922	Parts List Drawing For 1000/2000 PPD Ejectors
Drawing A-2000	Parts List Drawing For 1000/2000 PPD Check Valve Assembly
Application Bulletin 1002	Ejector Nozzle Requirements For 500 PPD And Below Ejectors
Application Bulletin 1009	Ejector Nozzle Requirements For 1000/2000 PPD Ejectors

QUALIFYING STATEMENT

These instructions pertain to all REGAL Chlorinator ejectors to 2000 lbs./day, all Sulphonator ejectors to 500 PPD, and all Ammoniator ejectors to 100 PPD. The photos and drawings used in this bulletin are general in nature and may not depict the specific REGAL ejector furnished with your system. **REFER TO THE REGAL EJECTOR PARTS LIST DRAWINGS IN THIS BULLETIN FOR CORRECT PART AND ASSEMBLY NUMBERS.**

1.0 INSTALLATION OF EJECTORS TO 500 PPD (See Photos No. 1, 2, 3 and 4)

- 1.1** The check valve in the ejector is designed in such a manner that the ejector may be installed in any position.

NOTE: If high pressure ejectors are to be used in low pressure installations (>20 psig), it is recommended that the ejector be installed so the vacuum tube connector points downward so gravity can help provide an effective, watertight seal of the check valve. A SECONDARY CHECK VALVE SHOULD BE CONSIDERED IN THESE INSTANCES. (Photos No. 12 and 13).

- 1.2** The point of injection should be carefully chosen so that the water pressure at this point is as low as possible. Water supply pressure to the nozzle **MUST** be high enough to overcome total system back pressure. REFER TO APPLICATION BULLETIN 1002.
- 1.2.1 All REGAL low pressure ejector assemblies are designed for total system back pressures up to 20 psig.
- 1.2.2 All REGAL high pressure ejector assemblies are designed for total system back pressures from 20 psig to 200 psig as standard.
- 1.3** Generally, the amount of water (GPM) required to operate the ejector depends upon the chemical flow rates needed (lbs./day or gms./hr). The higher the chemical flow rate, the greater the water flow needed. REFER TO APPLICATION BULLETIN 1002.
- 1.4** The water supply pressure needed to create the necessary operating vacuum is dependent upon the pressure into which the chemical solution is injected. Therefore, it is important that the minimum pressure differential and water flow for your installation be determined prior to installation and start-up. REFER TO APPLICATION BULLETIN 1002.

- 1.5** Follow these steps for installing close-coupled diffuser and ejector.
- 1.5.1 Unscrew the diffuser from the assembly. DO NOT install the diffuser when assembled as damage to component parts may occur.
- 1.5.2 Put Teflon pipe thread tape on the 3/4" pipe threads and screw the diffuser into the pipe. These are high-impact plastic parts, but like all plastic pipe fittings, care should be exercised in tightening. Tighten carefully with properly adjusted wrench. See Photo No. 1.

NOTE: Make sure the diffuser outlet holes are in the main stream. The end of an open type diffuser should not allow strong chlorine or sulfur dioxide solution to come in contact with the wall of the pipe or fittings as serious corrosion will result. See Photo No. 1.

- 1.5.3 Place a gasket into the recess on each side of the check valve body. Insert the nozzle through the check valve body (See Photo No. 2). Hold the check valve body against the diffuser at 1/8 turn COUNTER CLOCKWISE from its final position. See Photo No. 3. The check valve may be installed in any position (up, down, sideways).
- 1.5.4 Screw the nozzle into the diffuser by hand until contact is made against both gaskets. Turn the check valve body and the nozzle, at the same time, 1/8 turn clockwise to the final, tight position. See Photo. No. 3.
- 1.5.5 Attach water supply hose (or pipe) and tighten clamps. See Photo No. 4.

- 1.6** Other types of diffuser and ejector installations are possible depending on the needs of the installation. See Drawings No. 1 and 2.
- 1.6.1 Sometimes, the ejector assembly is mounted near the gas feed system components. In this instance, a wall mounting bracket for the ejector can be provided, and the ejector outlet can be supplied with various size adapters for solution hose or pipe.
- 1.6.2 If the ejector is to be remotely installed with solution pipe or hose running to the point of application, be certain to cut off the tip of the diffuser before installing into the pipe or hose. **FAILURE TO DO THIS WILL RESULT IN EXCESSIVE BACK PRESSURE CAUSING LOSS OF OPERATING VACUUM.**
- 1.6.3 The entire ejector assembly may be submersed in an open channel or tank.
- 1.6.4 Special diffuser outlets can be used with PVC ball valves. See Drawings No. 1 and 2.

2.0 INSTALLATION OF 1000/2000 PPD EJECTORS

- 2.1** The check valve in the ejector is designed so that the ejector may be installed in any position. The check valve assembly, components, and piping **MUST** be supported to prevent breakage due to water hammer, vibration, etc. A horizontal mounting of the ejector is preferred.
- 2.2** The point of injection should be carefully chosen so that water pressure is as low as possible. Vacuum is created in the ejector by the nozzle so water pressure to the nozzle must be high enough to overcome the back pressure and create a strong jet in the nozzle.
- 2.3** The standard ejector is designed to withstand static back pressures up to 70 psig (4.9 kg/cm²).
- 2.4** Generally, the amount of water (GPM) required to operate the ejector depends on the chemical feed rate (lbs/24 hrs. or kg/hr). The higher the chlorine feed rate, the greater the water flow needed. REFER TO APPLICATION BULLETIN 1009 IN THIS MANUAL.
- 2.5** Ejector water supply pressure must be greater than the pressure into which the chemical solution is injected. The amount of pressure differential may vary with the application. Generally, the greater the pressure into which the chemical will be injected, the greater the differential pressure must be. However, the minimum pressure differential and water flow for your installation should be determined prior to installation and start-up. REFER TO APPLICATION BULLETIN 1009 IN THIS MANUAL.
- 2.6** Follow these steps for installing the ejector assembly.
- 2.6.1 The nozzle (water) inlet and throat (chemical solution) outlet connections are 2" NPT for use with customer furnished fittings, flanges, unions, etc.
- 2.6.2 The ejector chemical gas inlet connection is 1" NPT.
- 2.6.3 Use teflon tape on all threaded connections. Tighten threaded connections carefully, using properly sized wrenches, and being careful not to over tighten, as damage to the parts could result.

3.0 PIPING OF EJECTOR

- 3.1** For most 500 PPD and below ejector applications, the ejector water supply line should be brought to within 3'-5' of the nozzle using rigid pipe materials.

For most 1000/2000 PPD ejector applications, the water and solution lines will be rigid sch. 80 PVC pipe.

- 3.2** Shut-off valves, unions, y-strainers, gauges, etc., are valuable service tools and are recommended. See Drawing No. 1.
- 3.3** For 500 PPD and below ejectors, connect a flexible hose line between the rigid incoming ejector water supply line and the ejector nozzle. Clamp the hose securely at both ends with single or double clamps. See Photo No. 4.

4.0 START-UP

- 4.1** The ejector, with its water supply and solution lines or piping must be properly installed and operating before checking the chlorinator, sulphonorator or ammoniator.
- 4.2** Unless the ejector is creating a vacuum, the chlorinator, sulphonorator or ammoniator **WILL NOT** work. Follow these steps:
- 4.2.1 For 500 PPD and below ejectors, disconnect the vacuum tubing at the ejector fitting. For 1000/2000 PPD ejectors, unscrew the 1" PVC union at the ejector vacuum connection.
- 4.2.2 With the booster pump running or the pressurized water supply connected, open the ejector water line supply valve and any other valves that may exist between the ejector outlet and the point of chemical application. The ejector should now be in operation and creating a strong vacuum.
- 4.2.3. For 500 PPD and below ejectors, check for proper vacuum by placing your finger against the vacuum tubing connector opening. For 1000/2000PPD ejectors, place your hand over the vacuum union opening.
- A STRONG VACUUM SHOULD EXIST. If there is no vacuum or only a weak vacuum, be certain that water supply pressure and flow is sufficient and that the nozzle and piping is not plugged. **CORRECT THE CONDITION AND OBTAIN PROPER VACUUM BEFORE PROCEEDING.**
- 4.2.4 Shut off the water supply to the ejector and make sure no water comes out of the vacuum tubing connector. If water is observed leaking past the check valve, correct before proceeding. Once the problem is corrected, cycle the ejector on and off a few times to make sure the check valve is tightly sealed. Water leaks at this point **CANNOT** be tolerated.
- 4.2.5 Reconnect the vacuum tubing or piping to the ejector fitting.

5.0 SERVICE/DISASSEMBLY

PREVENTIVE MAINTENANCE SCHEDULE REGAL SYSTEMS AND SYSTEM COMPONENTS

The best, most cost effective, and easiest way to assure that your gas feed system and equipment will provide continuous, dependable, trouble free operation, is to establish a PREVENTIVE MAINTENANCE SCHEDULE. This will assure minimum unscheduled down time. The maintenance schedule should be in writing and include as a minimum, the date of installation, the scheduled date of maintenance, the actual date the maintenance was performed, the parts used, and any applicable notes.

All REGAL products are engineered for easy maintenance and this manual provides step by step procedures to properly service and maintain each component within the system. It is your, (the customer's) responsibility to establish and undertake a SCHEDULED MAINTENANCE PROGRAM.

To support this program, we have available a variety of "REPAIR KITS" containing the parts we feel you may need for minor emergency repairs. We recommend that these kits be available in your stock at all times. When this kit, or any parts are used, the kit should be replaced immediately. This manual contains complete parts lists for each system component. As such, you can order and stock additional parts as deemed necessary.

AT A MINIMUM, THIS EQUIPMENT SHOULD RECEIVE SCHEDULED MAINTENANCE AT LEAST ONCE A YEAR. Depending on the installation, application, location of components, quality of gas, etc., this equipment may need scheduled maintenance more than once a year. This is something that needs to be determined on a job by job basis.

Spare parts and/or repair kits may be ordered directly from the company who supplied your equipment, or they may be ordered directly from our inventory in Stuart, Florida.

IMPORTANT: Maintenance on REGAL Systems or System Components should be performed by competent personnel familiar with this type of equipment such as; authorized REGAL Dealers or, Chlorinators Incorporated themselves.

WARNING: Even if the gas feed rate drops to zero as evidenced by the position of the ball or float in the metering tube and/or the out of gas indicator, and even if the supply container appears to be empty, SOME LIQUID CHEMICAL MAY STILL BE LEFT IN THE CYLINDER OR CONTAINER.

NEVER disconnect the vacuum regulator from the cylinder or container/manifold valve until ALL cylinder, container, or manifold valves are FULLY CLOSED or a highly dangerous chemical leak causing severe injuries or death could occur.

CYLINDER AND CONTAINER VALVES ARE ALWAYS CLOSED BY TURNING THE VALVE STEM IN A CLOCKWISE DIRECTION.

GENERAL

A check valve is installed in the ejector to prevent water from backing into the gas feed system components when the ejector is shut off. If dirt or impurities from the chemical source, or from the water supply line lodge between the check valve and its seat, water will back into the system requiring cleaning or replacement of the check valve components.

IMPORTANT: The photos and drawings in this instruction bulletin should be viewed and used with this procedure as necessary.

Section 5.1 - Service procedures for all REGAL HIGH PRESSURE Ejectors to 500 PPD.

Section 5.2 - Service procedures for all REGAL (OPTIONAL) LOW PRESSURE Ejectors to 500 PPD.

Section 5.3 - Service procedures for the REGAL (OPTIONAL) A-927 HIGH/LOW Ejector Check Valve to 100 PPD.

Section 5.4 - Service procedures for the REGAL (OPTIONAL) A-950 DUAL CHECK VALVE Ejector to 500 PPD.

Section 5.5 - Service procedures for all REGAL 1000/2000 PPD Ejectors.

Section 5.6 - Cleaning/Inspection of REGAL Ejector Nozzles to 500 PPD.

Section 5.7 - Cleaning/Inspection of REGAL Ejector Nozzles at 1000/2000 PPD.

5.1 HIGH PRESSURE EJECTORS ONLY TO 500 PPD

(See Drawing A-920/A-922/A-925)

- 5.1.1 Shut off the water supply to the ejector and the water in the main.
- 5.1.2 Remove the vacuum tubing.

NOTE: CHLORINE GAS TRAPPED BETWEEN THE VACUUM REGULATOR AND EJECTOR MAY DISCHARGE INTO THE ATMOSPHERE WHEN THE VACUUM LINE IS DISCONNECTED.

- 5.1.3 Unscrew the check valve seat counter clockwise and remove it from the ejector body. Use a pair of pliers if necessary.
- 5.1.4 Carefully lift the edge of the check valve (See Photo No. 5) and inspect for dirt and deposits. Clean both the valve and seating surface as necessary.
- 5.1.5 When reinstalling the check valve seat, put a small amount of Vaseline petroleum jelly or Dow Corning DC33 Silicone grease on the seat o-ring and gasket for lubrication.
- 5.1.6 Screw the check valve seat (clockwise) into the ejector body. USE NO TOOLS, HAND TIGHTEN ONLY.

- 5.1.7 Cycle the ejector on and off several times before reconnecting the vacuum tubing to ensure that the check valve is sealing properly.

REPLACING THE HIGH PRESSURE EJECTOR CHECK VALVE ON EJECTORS TO 500 PPD.

- 5.1.8 After inspecting the check valve as described above, if wear or damage is noted, the check valve should be replaced. Proceed as follows:
- Grasp the outer edges of the check valve and apply a steady pulling force until the "umbrella" tip pops free of the seat. Be certain it is completely removed.
 - Examine the check valve seat sealing surface for deposits and clean with warm water or alcohol.
 - Check the seat sealing surface with a straight edge to be sure that it is completely flat. If the center of the seat is slightly raised, you will see light under the straight edge or it will "rock" over the center. If the seat sealing surface is not flat, use a very fine sand paper or emery cloth on a flat surface (plate glass), and gently sand the check valve seat in a figure 8 pattern only. See Photo No. 6.
 - Coat the tip of a new check valve with a very light film of Vaseline petroleum jelly or DC33 Silicone grease. Put the tip of the check valve in the check valve seat hole and, using the handle of a screwdriver or other rounded object, push against the center of the check valve until the tip snaps into the seat. See Photo No. 7. **DO NOT TWIST THE CHECK VALVE OR DAMAGE MAY OCCUR.**
 - Examine the check valve seat o-ring and gasket for wear or damage and replace as necessary.
 - When reinstalling the check valve seat, put a small amount of Vaseline petroleum jelly or DC33 Silicone grease on the seat o-ring and seat gasket for lubrication.
 - Screw the check valve seat (clockwise) into the ejector body. **USE NO TOOLS. HAND TIGHTEN ONLY.**

5.2 OPTIONAL LOW PRESSURE EJECTOR CHECK VALVE TO 500 PPD- CLEANING AND REPLACING

(See appropriate Parts Drawing A-921/A-923/A-926, A-921S/A-923S/A-926S or A-921A)

- 5.2.1 To remove and clean the check valve, proceed as follows:
- Close the cylinder/container/manifold valve(s) before working on any system component.
 - Shut off the water supply to the ejector and the water pressure in the main.
 - Remove the vacuum tubing from the fitting on top of the ejector assembly.

- Unscrew (counterclockwise) the entire **check valve assembly** out of the **ejector body**. Make sure the seat gasket remains in place and is in good condition. Replace if necessary.
- Using a "spanner" wrench in the holes located in the underside of the **outlet body**, unscrew the **outlet body** from the **clamping ring**. Do not lose the **spring** or the **diaphragm assembly**.
 - The **diaphragm** is made from a special corrosion resistant plastic. Inspect it carefully for nicks or cuts. Replace as necessary.
 - The check valve action is accomplished by the **diaphragm bolt** sealing tightly on the **o-ring** located in the center of the **inlet body** when the ejector is shut off. As such, the **diaphragm bolt** sealing surface and the **o-ring** must be free of dirt or impurities that may prevent an effective seal. Clean or replace as necessary.
- Reassemble by reversing steps "a" through "d" above.

5.3 OPTIONAL A-927 HIGH/LOW EJECTOR CHECK VALVE TO 100 PPD - CLEANING & REPLACING

(See Parts Drawing A-927/A-927A)

- 5.3.1 The high/low check valve assembly is installed in the ejector assembly to prevent water from backing into the system when the ejector is shut off. If flooding has occurred or maintenance is due, proceed as follows:
- Close the cylinder/container/manifold valve (s) before working on any system component.
 - Shut off the water supply to the ejector and the water pressure in the main.
 - Remove vacuum tubing from the fitting on top of the ejector assembly.
 - Unscrew (counterclockwise) the entire **check valve assembly** out of the **ejector body**. Make sure the seat gasket remains in place and is in good condition. Replace if necessary.
 - Grasp the outer edges of the **check valve**, E-250, and apply a steady pulling force until the "umbrella" shaped stem "pops" free. Be certain it is completely removed.
 - Examine the **check valve seat** sealing surface for deposits, and clean with denatured alcohol.
 - Check the seat sealing surface with a straight edge to be certain it is completely flat. If the center is slightly raised, you will see light under the straight edge, or it will "rock" over the center. If the seat sealing surface is not flat, use a very fine sandpaper or emery cloth on a flat surface (e.g., plate glass) and gently move the **check valve seat** in a figure 8 pattern (Photo 6). Do not rub back and forth, or the seat will become distorted.

- h. Using a new E-250, wet the tip of the new **check valve** with a very light film (make shiny only) of Vaseline or Dow Corning DC33. Put the tip of the **check valve** in the "center" **check valve seat** hole and, using the handle of a screwdriver or other rounded object, push against the center of the **check valve** until the tip snaps into the seat (Photo 7). **DO NOT TWIST THE CHECK VALVE OR DAMAGE MAY OCCUR.**
- i. Using a "spanner" wrench in the holes located in the underside of the **outlet body**, unscrew the **outlet body** from the **clamping ring**. Do not lose the **spring** or the **diaphragm assembly**.
 - 1) The **diaphragm** is made from a special corrosion resistant plastic. Inspect it carefully for nicks or cuts. Replace as necessary.
 - 2) The check valve action is accomplished by the **diaphragm bolt** sealing tightly on the **o-ring** located in the center of the **inlet body** when the ejector is shut off. As such, the **diaphragm bolt** sealing surface and the **o-ring** must be free of dirt or impurities that may prevent an effective seal. Clean all parts or replace as necessary. Always use a new **check valve seal o-ring**.
- j. Reassemble, using a spanner wrench in holes, located in underside of outlet body. Tighten outlet body and clamp ring.
- k. When reinstalling the **check valve assembly** in ejector, put a thin film of Vaseline or Dow Corning DC33 on the **seat o-ring** and **seat gasket** for lubrication. Use very sparingly (make it shiny only). **DO NOT USE ANY OTHER PETROLEUM BASED GREASES OR OILS.**
- l. Screw the **check valve assembly** clockwise into the ejector body. Use no tools. **Hand tighten only.**
- m. Pressurize the ejector and cycle on and off several times before reconnecting the vacuum tubing to ensure that the check valve is sealing properly. Follow start-up procedures in Section 4.0.

5.4 OPTIONAL DUAL CHECK VALVE EJECTOR TO 500 PPD

(See Drawing A-950/A-949)

The NEW REGAL A-950 Dual Check Valve Ejector has a ball check valve as the primary check valve backed up by a spring loaded o-ring/poppet check valve. To service this check valve, proceed as follows:

- 5.4.1 Shut off the water supply to the ejector and the water in the main.
- 5.4.2 Remove the vacuum tubing.

NOTE: CHLORINE GAS TRAPPED BETWEEN THE VACUUM REGULATOR AND EJECTOR MAY DISCHARGE INTO THE ATMOSPHERE WHEN THE VACUUM LINE IS DISCONNECTED.

- 5.4.3 Unscrew (counter clockwise) the complete A-949 Check Valve Assembly from ejector body E-557. A properly sized wrench can be used on the machined "flats" of bottom body E-552 if necessary to loosen the ejector body. **DO NOT USE PLIERS.**
- 5.4.4 Make sure the o-ring S-413 located on bottom body E-552 is in good shape. Replace as necessary.
- 5.4.5 To gain access to the check valve components, unscrew (counter clockwise) clamp ring E-301 from bottom body E-552 and lift the top body E-551 with the clamp ring off of the bottom body. **BE CAREFUL NOT TO LOSE POPPET E-554, SPRING E-555, OR O-RING S-416 AS THESE ITEMS CAN EASILY FALL OUT.**
- 5.4.6 Inspect the o-ring S-418 located on the E-554 poppet and replace as necessary. **THIS IS THE SECONDARY CHECK VALVE SEAL AND MUST BE IN LIKE NEW CONDITION.**
- 5.4.7 Inspect and clean as necessary the flat surface inside top body E-551. Since this is the sealing surface for the S-418 sealing o-ring, **THIS SURFACE MUST BE CLEAN AND PERFECTLY FLAT.**
- 5.4.8 The primary check valve is located inside bottom body E-552. To gain access to the primary check valve, proceed as follows:
 - a. Using Drawing A-950/A-949 as a guide, carefully unscrew (counter clockwise) the spring/ball retainer E-553 from bottom body E-552. **THE OUTER CIRCUMFERENCE OF THE SPRING/BALL RETAINER IS KNURLED TO MAKE IT EASIER TO UNSCREW.**
ONCE REMOVED, THE BALL E-556 IS FREE TO FALL OUT. BE CAREFUL NOT TO LOSE OR DAMAGE THE BALL.
 - b. Inspect the ball E-556 and make sure it is free of all deposits, nicks, and pits. If in doubt, replace as necessary.
 - c. Poppet E-553 contains two o-rings. The S-415 o-ring is a sealing o-ring and **MUST** remain in its groove when reassembling the check valve components. Inspect this o-ring for wear and replace as necessary.
 - d. The second poppet o-ring S-417 is a critical o-ring as it is the sealing surface for the primary check device (ball E-556). This o-ring is located in an undercut groove at the base of spring/ball retainer E-553.

If o-ring S-417 shows any signs of wear or, if o-ring S-417 is flattened due to the check action of ball E-556, replace with a new one.
- 5.4.9 Clean all check valve parts with warm water and/or a mild solvent such as denatured alcohol.
- 5.4.10 Make sure all parts are thoroughly dry and all o-rings are in place and reassemble by reversing the steps outlined in Section 5.4.

5.5 EJECTOR CHECK VALVE 1000/2000PPD - CLEANING OR REPLACING

(Refer to Drawing A-2920/2922)

5.5.1 A-2000 CHECK VALVE

A **check valve** is installed in the ejector assembly to prevent water from backing into the system when the ejector is shut off. The **check valve** design is such that it is extremely difficult for dirt to lodge under the valve, but it might, if large amounts of sand or other impurities are present in the water supply; and dirt could possibly enter from the chemical side. To remove and clean the valve, proceed as follows:

- a. Close the manifold valve that the vacuum regulator is attached to before working on any system components.
- b. Shut off the water supply to the ejector and the water pressure in the main.
- c. Open the 1" **PVC vacuum union** MS-19 by unscrewing (counter clockwise) the union ring and move the vacuum piping out of the way. Be careful not to lose the **vacuum union o-ring**.

NOTE: CHLORINE GAS TRAPPED BETWEEN THE VACUUM REGULATOR AND EJECTOR MAY DISCHARGE INTO THE ATMOSPHERE WHEN THE VACUUM LINE IS DISCONNECTED.

- d. Using Parts List Drawing A-2000 as a guide, unscrew **clamp ring** CV-2004 and lift the **top body** CV-2002 with **clamp ring** off **bottom body** CV-2001 and set aside. BE SURE NOT TO LOSE O-RING S-804.
- e. Carefully lift out **poppet** CV-2003 and **spring** CV-2005.
- f. **Poppet** CV-2003 contains an **o-ring** S-805 which is the **check valve seal**. THIS O-RING MUST BE IN PERFECT SHAPE, FREE OF NICKS, CUTS, ETC. IF NECESSARY, REPLACE IT WITH A NEW ONE.
IF O-RING S-805 SHOWS SIGNS OF BEING FLATTENED DUE TO THE ACTION OF THE CHECK VALVE, REPLACE IT WITH A NEW ONE.
- g. Inspect the flat surface inside **top body** CV-2002 to be sure it is flat and clean. THIS IS THE SURFACE O-RING S-805 SEALS AGAINST.
- h. Clean all check valve parts with warm water or a mild solvent such as alcohol and dry thoroughly.
- i. Reassemble the ejector check valve assembly by reversing steps "a" through "e".

5.6 CLEANING/INSPECTION OF EJECTOR NOZZLE TO 500 PPD

- 5.6.1 To remove the ejector nozzle for cleaning, the water pressure in the main must first be shut off unless the ejector was initially installed with a valve on the inlet side and a ball valve or corporation stop in the outlet, so that isolation of the ejector is possible.
 - a. Close the cylinder/container/manifold valve(s) before working on any system component.
- 5.6.2 Remove the ejector supply hose and gas vacuum tubing from the ejector assembly.
- 5.6.3 Rotate the complete **ejector body** counterclockwise, making certain that the solution **diffuser** remains fixed in the solution piping or main. (Photo 1).
- 5.6.4 Unscrew the **nozzle** from the **ejector body**. Check the **gaskets** located in each side of the body and replace if necessary. (Photo 3).
- 5.6.5 Nozzle plugging can be caused by:
 - a. A piece of foreign material (pipe sealer, stone, or dirt) lodging in the nozzle orifice. This can usually be blown out in the reverse direction. DO NOT USE SHARP TOOLS OR ALTER THE SIZE OF THE ORIFICE IN ANY WAY.
 - b. Excess plastic pipe solvent or glue used during initial installation running into the orifice area of the nozzle. If this cannot be cleaned out easily, the nozzle may need to be replaced.
 - c. Build-up of deposit. This could be a chemical build-up or iron, manganese, or some other material which usually can be removed by immersing the nozzle in muriatic acid and rinsing. CAUTION: READ ALL WARNING LABELS ON THE MURIATIC ACID CONTAINER, AND AVOID SKIN CONTACT. It is recommended that safety goggles or face shield be used when working with any strong acid. Some waters are such that build-up of deposits can cause an ejector to become inoperative in a short period of time.
- 5.6.6 To reinstall the **nozzle**:
 - a. Insert the **nozzle** through the **ejector body** and screw into the solution **diffuser**. Make sure the **gaskets** are in place and in good condition. (Photo 3).
 - b. Hold the **ejector body** against the **diffuser** at 1/8 turn counterclockwise from its final position. (Photo 3).
 - c. Screw the **nozzle** into the **diffuser** by hand until contact is made against both **gaskets**.
 - d. Turn the **ejector body** and the **nozzle** at the same time, 1/8 turn clockwise to the final tight position. THE PARTS ARE PLASTIC, AND EXCESSIVE TIGHTENING MAY CAUSE BREAKAGE. DO NOT USE TOOLS.
 - e. Reinstall the ejector supply hose and vacuum tubing. (Photo 4).
- 5.6.7 Open all valves and check for proper operating vacuum.

5.7 CLEANING /INSPECTION OF 1000/2000 PPD EJECTOR NOZZLE

5.7.1 The ejector nozzle and throat thread into the ejector body. To inspect and clean these parts, proceed as follows:

- a. Close the manifold valve that the vacuum regulator is attached to before working on any system component.
- b. Shut off the water supply pressure to the ejector, and close any valves in the chlorine solution line so as to isolate the ejector assembly.
- c. Open the **1" PVC vacuum union MS-19** by unscrewing (counter clockwise) the union ring and move the vacuum piping out of the way.

Be careful not to lose the vacuum union o-ring.

NOTE: CHLORINE GAS TRAPPED BETWEEN THE VACUUM REGULATOR AND EJECTOR MAY DISCHARGE INTO THE ATMOSPHERE WHEN THE VACUUM LINE IS DISCONNECTED.

- d. Open or disconnect the 2" unions, flanges, fittings, etc., holding the ejector assembly into the pipeline, and remove the ejector. WHEN REMOVING AND/OR INSTALLING THE COMPLETE EJECTOR ASSEMBLY, **BE CAREFUL NOT TO LOOSEN OR OVERTIGHTEN THE NOZZLE AND THROAT WHICH COULD CAUSE DAMAGE TO THESE PARTS AND/OR WATER LEAKS.**
- e. Carefully clean or remove any foreign material that may have accumulated in the ejector nozzle or throat area, being careful not to scratch or mar the nozzle orifice.

NOTE: DO NOT USE SHARP TOOLS OR ALTER THE SIZE OF THE ORIFICE IN ANY WAY.

- f. If chemical deposits have built up in the nozzle or throat area, immerse the part in muriatic acid. REMOVE ALL O-RINGS OR GASKETS FIRST.

IMPORTANT: READ ALL WARNING LABELS ON MURIATIC ACID CONTAINER AND FOLLOW ALL SAFETY INSTRUCTIONS.

- g. Reassemble by reversing steps "a" through "e".

6.0 SECONDARY CHECK VALVES FOR 500 PPD AND BELOW EJECTORS

If frequent ejector check valve failures causing flooding of the gas feed system components are a concern due to poor quality water, etc., Chlorinators Incorporated offers as an optional accessory "SECONDARY CHECK VALVE ASSEMBLIES." (See Photos 12 and 13).

The SECONDARY CHECK VALVE ASSEMBLY is installed in series with the primary check valve in the ejector. This now means that both the primary and the secondary check valves must fail in order to flood the remainder of the system components.

For best protection, the primary check valve device should be checked for failures as often as necessary and repaired as soon as a failure is detected. THE FREQUENCY OF CHECKING THE PRIMARY CHECK VALVE IS DETERMINED BY THE SYSTEM, THE QUALITY OF THE CHEMICAL BEING USED AND, THE QUALITY OF THE EJECTOR SOURCE WATER.

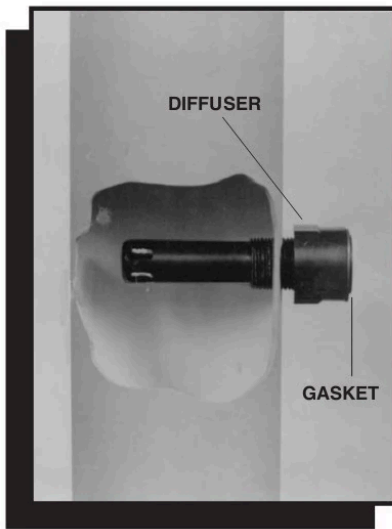

1

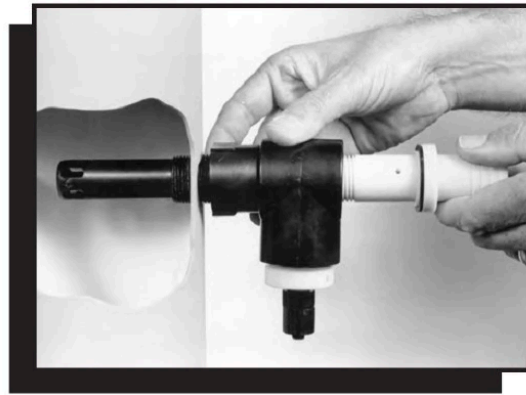

2

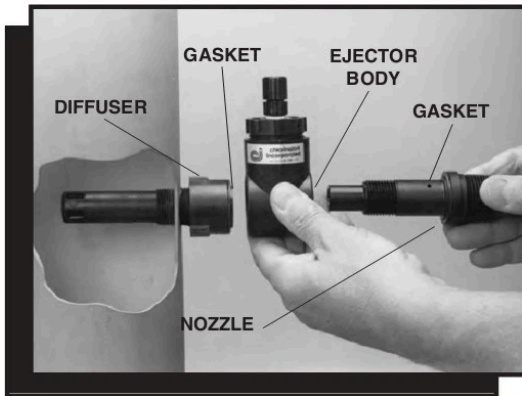

3

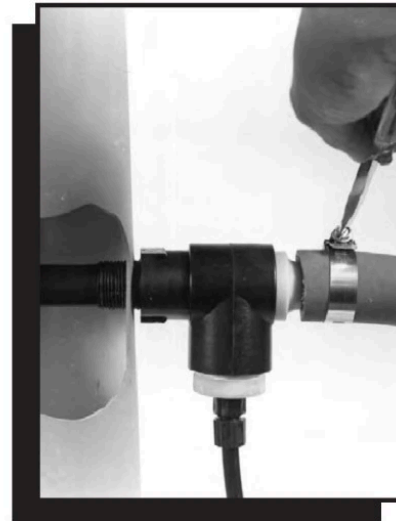

4

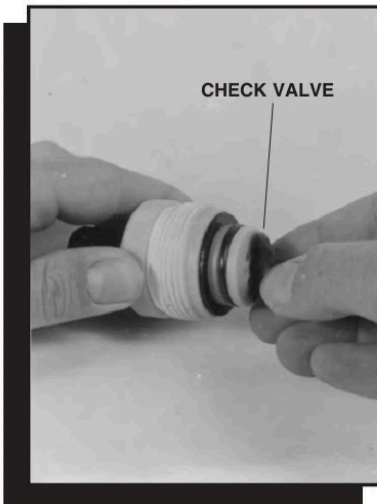

5

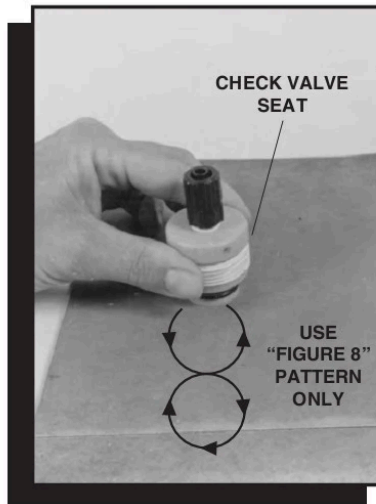

6

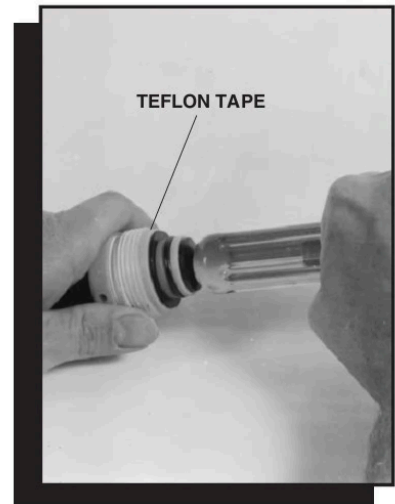

7

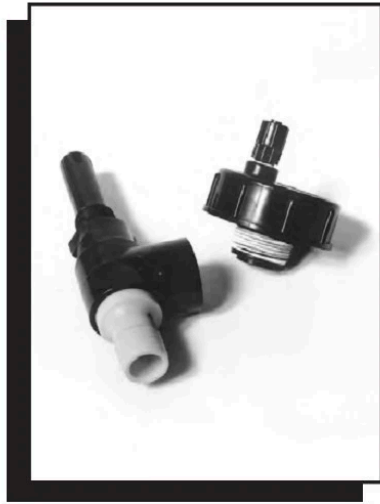

8



9

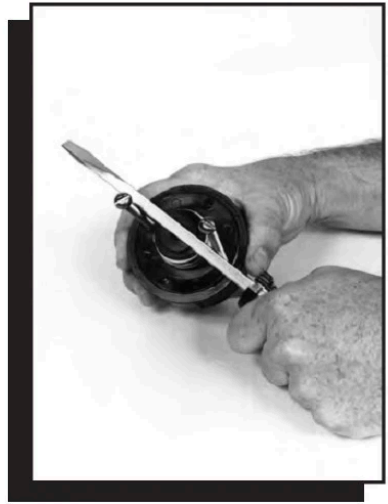

10

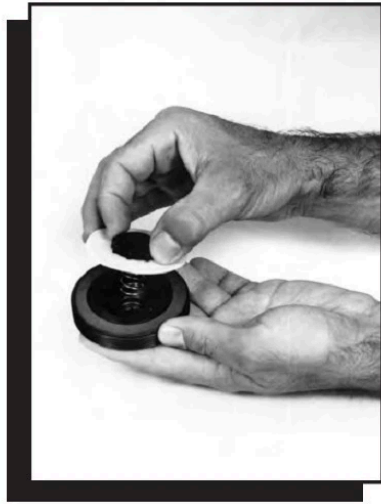

11



12



13

12

DRAWING NO. 1 Typical 500 PPD And Below Ejector Installations

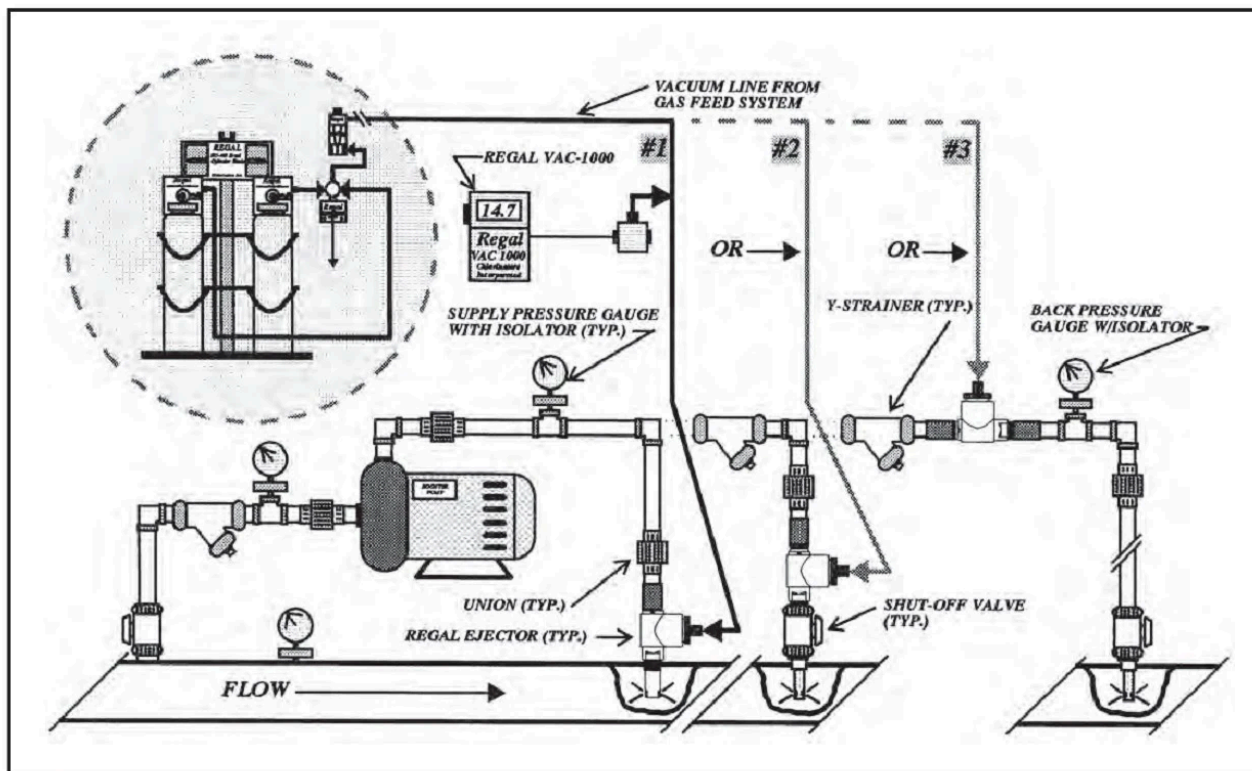

- #1 The ejector is installed directly at the application point using the standard spray diffuser furnished with most REGAL Gas Feed Systems. An advantage with this installation is that "total" back pressure is equal to the application point pressure and the booster pump therefore need only be large enough to supply the hydraulic requirements of the nozzle.
- A disadvantage with this installation is that the water main has to be shut down and de-pressurized in order to service the ejector assembly, booster pump, etc.
- #2 In this installation, the end of the standard spray diffuser is cut-off to allow unimpeded flow through the ejector. A corrosion resistant valve such as a PVC ball valve is then screwed onto the cut-off end of the diffuser and a remote spray or open end diffuser is screwed into the other end of the ball valve. The ejector with ball valve and remote diffuser is then installed directly at the application point.
- As long as the ball valve and diffuser are sized properly, this installation, like the #1 installation above, has the advantage of "total" back pressure being equal to the application point pressure plus an added advantage since the ejector, booster pump, etc. can now be serviced WITHOUT shutting down and/or de-pressurizing the water main.
- #3 Often, the ejector is installed remote from the application point. Even though this is an acceptable (but not the preferred) installation, special consideration must be given to the following:
- A chlorine solution line is a dangerous chlorine pressure line with a chlorine solution strength as high as 3500 parts per million. If this line breaks, the high concentration of chlorine will present a hazard to personnel and/or property.
 - The solution line and solution line fittings must be sized properly to assure that friction losses in this line DO NOT exceed 5' per 100' of equivalent pipe length.
 - A diaphragm protected pressure gauge should always be installed as close to the discharge side of the ejector as possible. This gauge provides a reading of "total" back pressure (application point pressure plus all additional pressures due to friction losses created by the solution line, fittings, elevation differences, etc.).

DRAWING NO. 2
Typical 100 PPD And Below Ejector Inlet And Outlet Connections

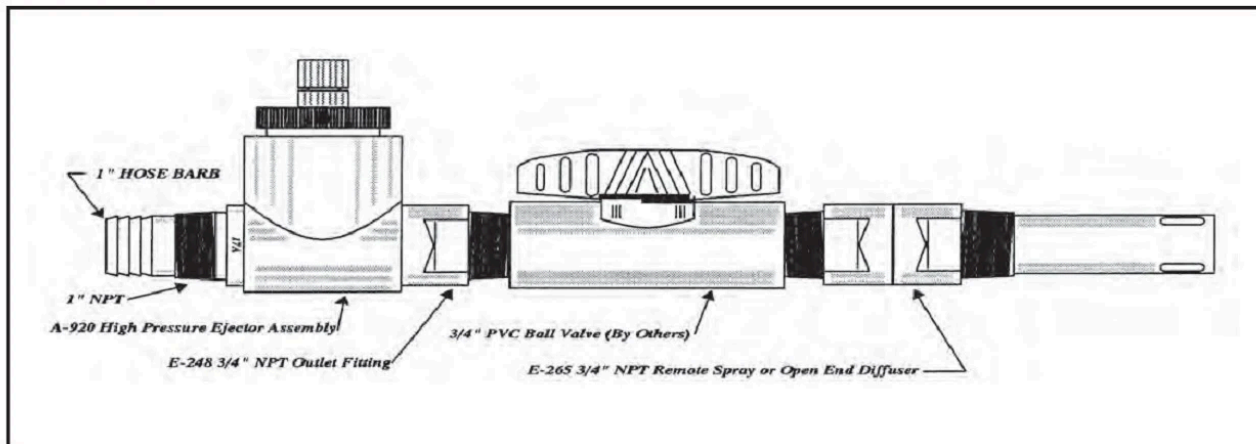

Ejector Installation with Ball Valve to Allow Positive Shut-off when Servicing of the Ejector is Required

NOTES:

1. This installation is suitable for back pressures up to 150 psig and gas feed rates up to 100 PPD.
2. If necessary, ejector can be installed at a remote location from the ball valve and diffuser.

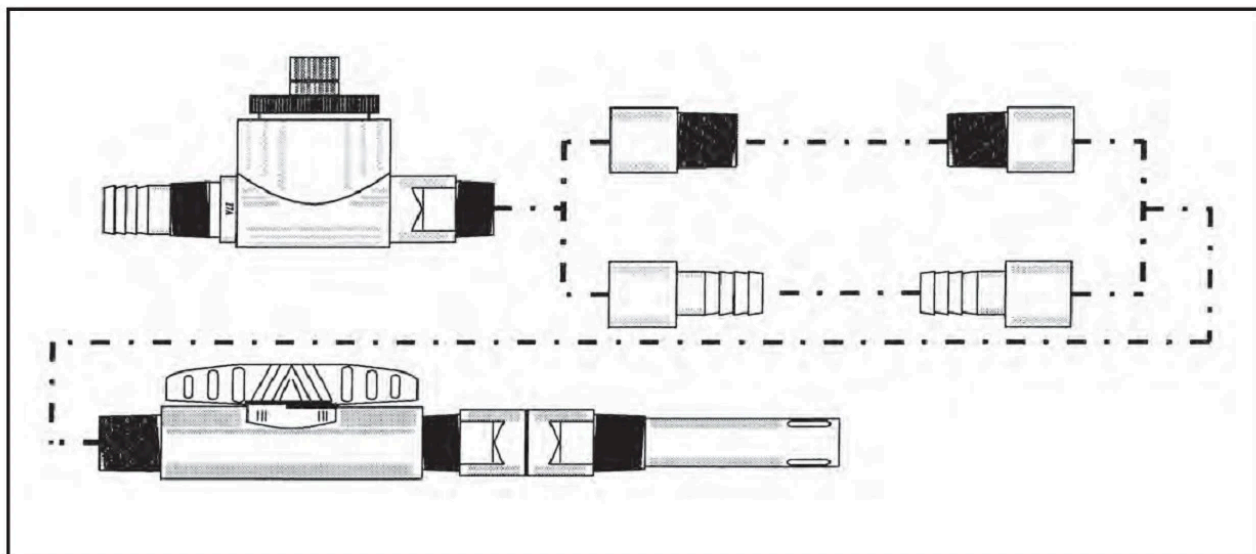

Remote Mounted Ejector Installation for Gas Feed Rates up to 100 PPD.

NOTE:

Threaded and hose interconnection sizes and ball valve size must be adequate to limit friction losses to a maximum of 5' per 100' of pipe or hose length.

DRAWING NO. 3
Typical Installation Of Remote Mounted Ejector
With Solution Line To Point Of Chemical Application

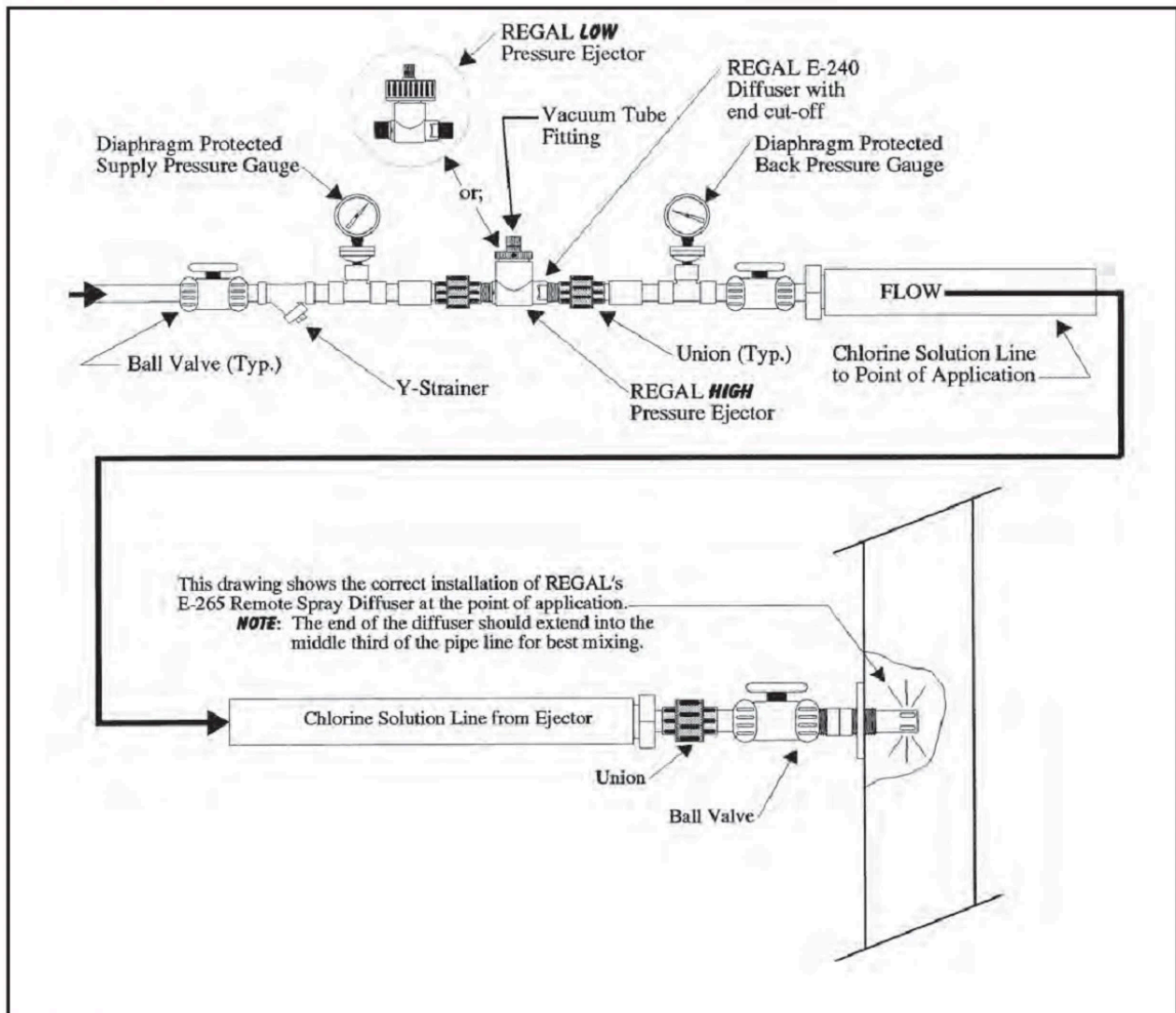

NOTE:

1. When the REGAL Ejector is mounted at a location remote from the application point, the end of the standard diffuser (E-240) **MUST** be cut off to allow unrestricted flow or, an E-248 1" long **open end** diffuser should be furnished with the system when ordered.
2. The chlorine solution line shown above is oversized to minimize additional back pressure due to friction losses. A rule of thumb is to keep friction losses to a maximum of 5' per 100' of equivalent pipe length. This calculation **MUST** take into consideration: elevation differences, number of elbows, valves, fittings, etc.
 A. Depending on the variables noted above, the water supply line to the ejector **MAY** need to be oversized as well.
3. To determine the hydraulic requirements needed to operate the REGAL Ejector, refer to Application Bulletin 1002 or 1009.

**DRAWING NO. A-920/A-922/A-925 Ejector Assembly (Standard)
E-225/E-227/E-525 Check Valve Assembly Chlorine Service
High Pressure - For Back Pressure Over 20 PSI (1.4KG/CM²)**

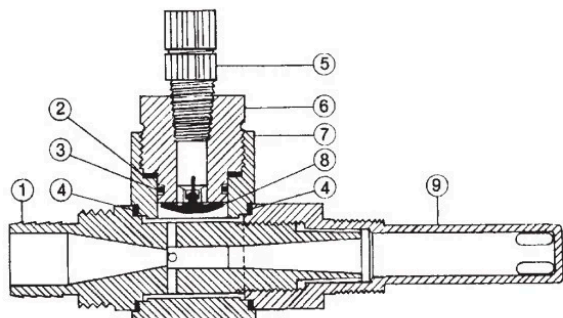

EJECTOR MODEL A-920
EJECTOR MODEL A-922

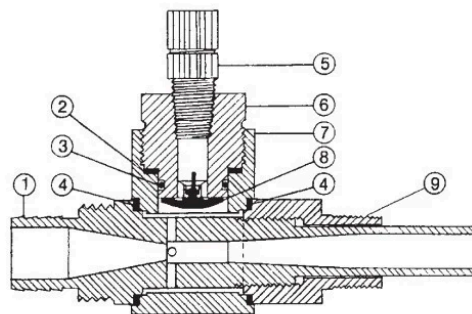

EJECTOR MODEL A-925

Ejector Assembly A-920

Check Valve Assembly E-225 Includes Ref. No. 2, 3, 5, 6, 8
Max. Capacity: 100 lbs./24 hrs. (2000 g/hr)

Ref. No.	Part No.	Quantity	Description
1	E-230 (3A,4A,5A) E-234 (17A)	1	Nozzle
2	G-203	1	Seat Gasket
3	S-405	1	Seat O-Ring
4	G-204	2	Body Gasket
5	Z-250	1	3/8" OD Tube Fitting
6	E-220	1	Check Valve Seat
7	E-210	1	Ejector Body
8	E-250	1	Check Valve
9	E-240	1	Diffuser

Ejector Assembly A-922

Check Valve Assembly E-227 Includes Ref. No. 2, 3, 5, 6, 8
Max. Capacity: 250 lbs./24 hrs. (5000 g/hr)

Ref. No.	Part No.	Quantity	Description
1	E-234 (18A)	1	Nozzle
2	G-203	2	Seat Gasket
3	S-405	1	Seat O-Ring
4	G-204	2	Body Gasket
5	ZZ-260	1	1/2" OD Tube Fitting
6	E-222	1	Check Valve Seat
7	E-210	1	Ejector Body
8	E-250	1	Check Valve
9	E-240	1	Diffuser

Ejector Assembly A-925

Check Valve Assembly E-525 Includes Ref. No. 2, 3, 5, 6, 8
Max. Capacity: 500 lbs./24 hrs. (10 kg/hr)

Ref. No.	Part No.	Quantity	Description
1	E-533 (50X)	1	Nozzle
2	G-203	2	Seat Gasket
3	S-405	1	Seat O-Ring
4	G-204	2	Body Gasket
5	ZZ-271	1	5/8" OD Tube Fitting
6	E-520	1	Check Valve Seat
7	E-210	1	Ejector Body
8	E-250	1	Check Valve
9	E-540	1	Nozzle Retainer

NOTE: Include Chlorinator Serial Number and Capacity and Size (OD) of Vacuum Tubing Being Used.

**DRAWING NO. A-920S/A-922S/A-925S Ejector Assembly (Standard)
E-225S/E-227S/E-525S Check Valve Assembly Sulfur Dioxide Service
High Pressure - For Back Pressure Over 20 PSI (1.4KG/CM2)**

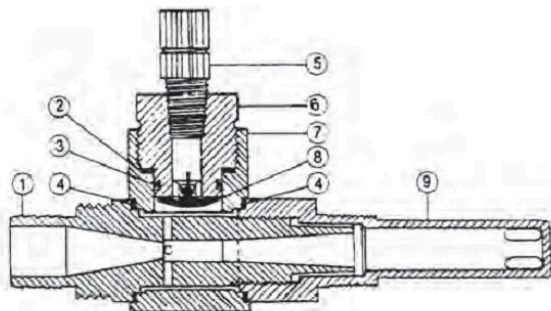

EJECTOR MODEL A-920S
EJECTOR MODEL A-922S

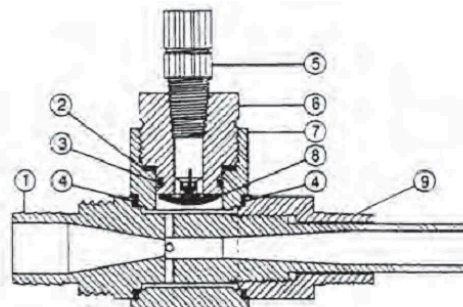

EJECTOR MODEL A-925S

Ejector Assembly A-920S

Check Valve Assembly E-225S Includes Ref. No. 2, 3, 5, 6, 8
Max. Capacity: 100 lbs./24 hrs. (2000 g/hr)

Ref. No.	Part No.	Quantity	Description
1	E-230 (3A, 4A, 5A) E-234 (17A)	1	Nozzle
2	G-203	1	Seat Gasket
3	S-405	1	Seat O-Ring
4	G-204	2	Body Gasket
5	ZZ-250	1	3/8" OD Tube Fitting
6	E-720	1	Check Valve Seat
7	E-710	1	Ejector Body
8	E-250	1	Check Valve
9	E-240	1	Diffuser

Ejector Assembly A-922S

Check Valve Assembly E-227S Includes Ref. No. 2, 3, 5, 6, 8
Max. Capacity: 250 lbs./24 hrs. (5000 g/hr)

Ref. No.	Part No.	Quantity	Description
1	E-234 (18A)	1	Nozzle
2	G-203	2	Seat Gasket
3	S-405	1	Seat O-Ring
4	G-204	2	Body Gasket
5	ZZ-260	1	1/2" OD Tube Fitting
6	E-722	1	Check Valve Seat
7	E-710	1	Ejector Body
8	E-250	1	Check Valve
9	E-240	1	Diffuser

Ejector Assembly A-925S

Check Valve Assembly E-525S Includes Ref. No. 2, 3, 5, 6, 8
Max. Capacity: 500 lbs./24 hrs. (10 kg/hr)

Ref. No.	Part No.	Quantity	Description
1	E-533 (50X)	1	Nozzle
2	G-203	2	Seat Gasket
3	S-405	1	Seat O-Ring
4	G-204	2	Body Gasket
5	ZZ-271	1	5/8" OD Tube Fitting x 3/8 NPT
6	E-725	1	Check Valve Seat
7	E-710	1	Ejector Body
8	E-250	1	Check Valve
9	E-540	1	Nozzle Retainer

NOTE: Include Sulphonator Serial Number and Capacity and Size (OD) of Vacuum Tubing Being Used.

**DRAWING NO. A-927/A-927A High/Low Pressure Ejector Assembly (Optional)
A-301/A-301A High/Low Pressure Check Valve Assembly
Chlorine/Ammonia Service - Max. Capacity: 100 PPD (2000GM/HR)**

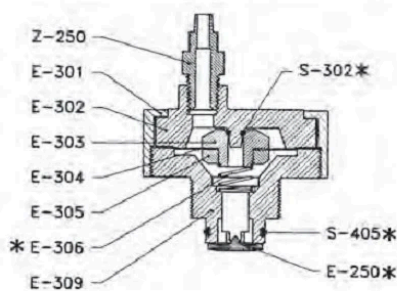

HIGH/LOW CHECK VALVE ASSEMBLY

A-301 CHLORINE SERVICE

Part No.	Quantity	Description
E-301	1	Clamp Ring
E-302	1	Inlet Body
E-303	1	Diaphragm Bolt
E-304	1	Diaphragm
E-305	1	Diaphragm Nut
* E-306	1	Spring
E-309	1	Outlet Body
* E-250	1	Check Valve
* S-302	1	O-Ring
* S-405	1	O-Ring
Z-250	1	Tube Fitting (3/8" OD)

* A-301A AMMONIA SERVICE

Substitute the following parts

E-310	1	Spring
EA-250	1	Check Valve
SA-302	1	O-Ring
SA-405	1	O-Ring

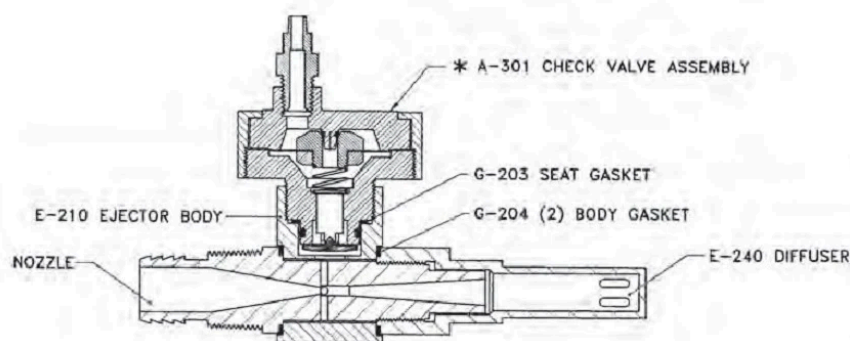

HIGH/LOW EJECTOR ASSEMBLY
MAX. 100 PPD (2000GM/HR)

A-927 CHLORINE SERVICE

Part No. Quantity Description

* A-301	1	High/Low C.V. Assembly
E-210	1	Ejector Body
E-240	1	Diffuser
G-203	1	Seat Gasket
G-204	2	Body Gasket
	1	Nozzle per PPD

* A-927A AMMONIA SERVICE

Substitute the following parts

A-301A	1	High/Low C.V. Assembly
--------	---	------------------------

**DRAWING NO. A-920A Ejector Assembly (Standard)
E-225A Check Valve Assembly Ammonia Service
High Pressure - For Back Pressure Over 20 PSI (1.4 KG/CM²)**

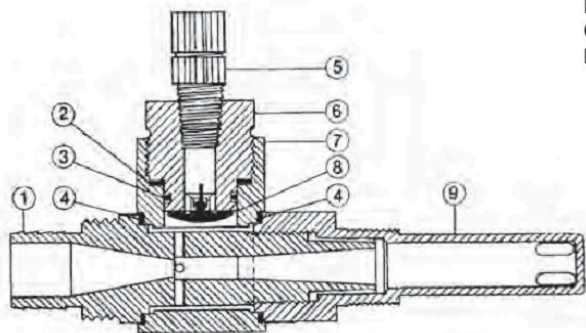

EJECTOR MODEL A-920A

Ejector Assembly A-920A

Check Valve Assembly E-225A Includes Ref No. 2, 3, 5, 6, 8
Max. Capacity: 100 lbs./24 hrs. (2000 g/hr)

Ref. No.	Part No.	Quantity	Description
1	E-230 (3A, 4A, 5A) E-234 (17A)	1	Nozzle
2	G-203	1	Seat Gasket
3	SA-405	1	Seat O-Ring
4	G-204	2	Body Gasket
5	Z-250	1	3/8" OD Tube Fitting
6	E-222	1	Check Valve Seat
7	E-210	1	Ejector Body
8	EA-250	1	Check Valve
9	E-240	1	Diffuser

NOTE: Include Ammoniator Serial Number, Capacity and Size (OD) of Vacuum Tubing Being Used.

**DRAWING NO. A-921/A-923/A-926 Ejector Assembly (Optional)
A-300/A-320/A-350 Check Valve Assembly Chlorine Service
Low Pressure - For Back Pressure Up to 20 PSI (1.4KG/CM2)**

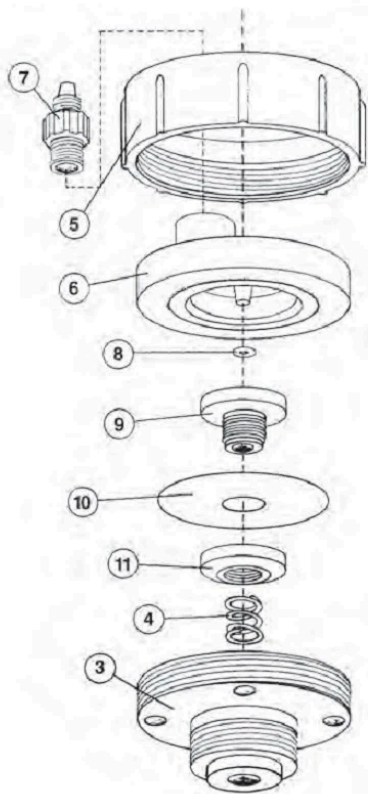

A-300/A-320/A-350
Low Pressure Check Valve Assembly

A-300 up to 100 lbs./24 hrs.
A-320 @ 250 lbs./24 hrs.
A-350 @ 500 lbs./24 hrs.

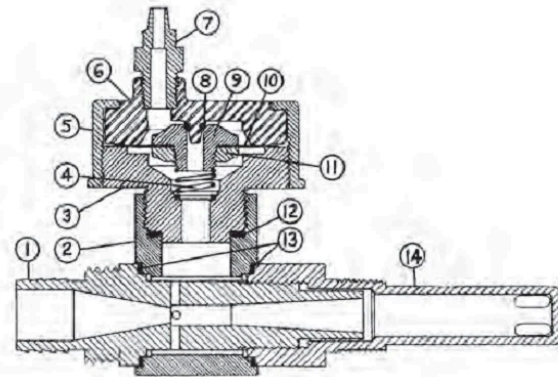

EJECTOR MODEL A-921 100 PPD (2000 g/hr.)
EJECTOR MODEL A-923 250 PPD (5000 g/hr.)

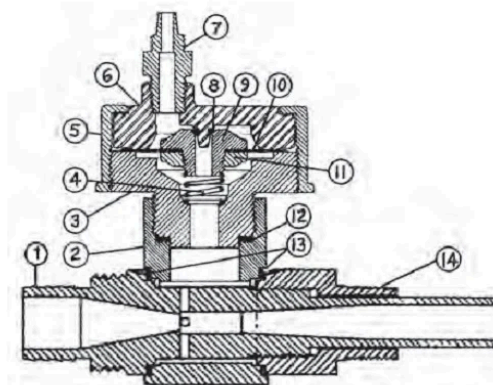

EJECTOR MODEL A-926 500 PPD (10 kg/hr.)

Ejector Assembly Max. Capacity	A-921 100 lbs./24hrs. (2000 g/hr)	A-923 250 lbs./24 hrs. (5000 g/hr)	A-926 500 lbs./24 hrs. (10 kg/hr)
-----------------------------------	--------------------------------------	---------------------------------------	--------------------------------------

Ref. No.	Part No.	Part No.	Part No.	Quantity	Description
1	E-230 (3A, 4A, 5A) E-234 (17A)	E-234 (18A)	E-533 (50X)	1	Nozzle
2	E-210	E-210	E-210	1	Ejector Body
3	E-307	E-307	E-307	1	Outlet Body
4	E-306	E-306	E-306	1	Spring
5	E-301	E-301	E-301	1	Clamping Ring
6	E-302	E-302	E-302	1	Inlet Body
7	Z-250 (3/8" OD)	ZZ-260 (1/2" OD)	ZZ-270 (5/8" OD)	1	Tube Fitting
8	S-302	S-302	S-302	1	Check Valve Seal
9	E-303	E-303	E-303	1	Diaphragm Bolt
10	E-304	E-304	E-304	1	Diaphragm
11	E-305	E-305	E-305	1	Diaphragm Nut
12	G-203	G-203	G-203	1	Seat Gasket
13	G-204	G-204	G-204	2	Body Gasket
14	E-240	E-240	E-540	1	Diffuser/Nozzle Retainer

NOTE: Include Chlorinator Serial Number and Capacity and Size (OD) of Vacuum Tubing Being Used.

**DRAWING NO. A-921S/A-923S/A-926S Ejector Assembly (Optional)
 A-300S/A-320S/A-350S Check Valve Assembly Sulfur Dioxide Service
 Low Pressure - For Back Pressure Up To 20 PSI (1.4KG/CM2)**

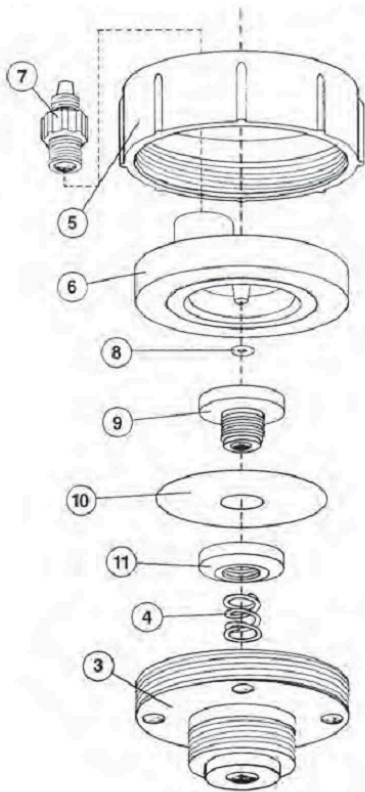

A-300S / A-320S / A-350S
 Low Pressure Check Valve Assembly

A-300S up to 100 lbs./24 hrs.
 A-320S @ 250 lbs./24 hrs.
 A-350S @ 500 lbs./24 hrs.

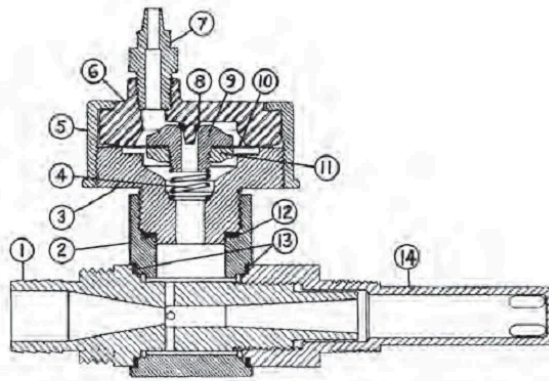

EJECTOR MODEL A-921S 100 PPD (2000 g/hr.)
 EJECTOR MODEL A-923S 250 PPD (5000 g/hr.)

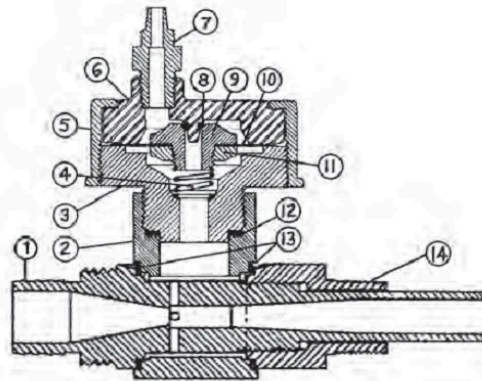

EJECTOR MODEL A-926S 500 PPD (10 kg/hr.)

Ejector Assembly Max. Capacity	A-921S 100 lbs./24hrs. (2000 g/hr)	A-923S 250 lbs./24 hrs. (5000 g/hr)	A-926S 500 lbs./24 hrs. (10 kg/hr)	Quantity	Description
Ref. No.	Part No.	Part No.	Part No.		
1	E-230 (3A, 4A, 5A) E-234 (17A)	E-234 (18A)	E-533 (50X)	1	Nozzle
2	E-710	E-710	E-710	1	Ejector Body
3	E-707	E-707	E-707	1	Outlet Body
4	E-310	E-310	E-310	1	Spring
5	E-701	E-701	E-701	1	Clamping Ring
6	E-702	E-702	E-702	1	Inlet Body
7	ZZ-250 (3/8" OD)	ZZ-260 (1/2" OD)	ZZ-270 (5/8" OD)	1	Tube Fitting
8	S-302	S-302	S-302	1	Check Valve Seal
9	E-703	E-703	E-703	1	Diaphragm Bolt
10	E-304	E-304	E-304	1	Diaphragm
11	E-705	E-705	E-705	1	Diaphragm Nut
12	G-203	G-203	G-203	1	Seat Gasket
13	G-204	G-204	G-204	2	Body Gasket
14	E-240	E-240	E-540	1	Diffuser/Nozzle Retainer

NOTE: Include Sulphonator Serial Number and Capacity and Size (OD) of Vacuum Tubing Being Used.

DRAWING NO. A-921A Ejector Assembly (Optional)
A-300A Check Valve Assembly Ammonia Service
Low Pressure - For Back Pressure Up to 20 PSI (1.4 KG/CM2)

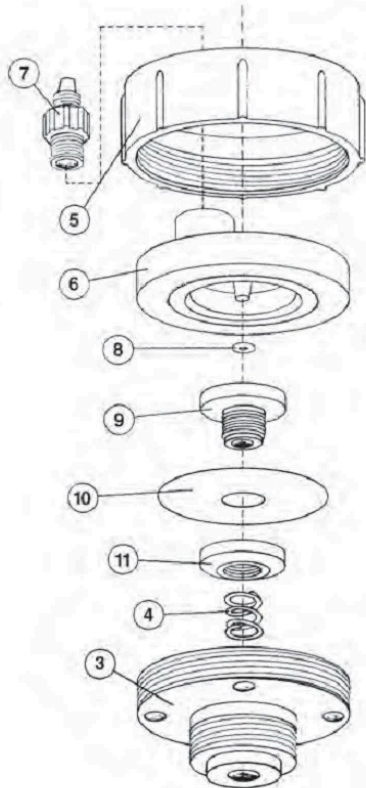

A-300A
 Low Pressure Check Valve Assembly

A-300A up to 100 lbs./24 hrs.

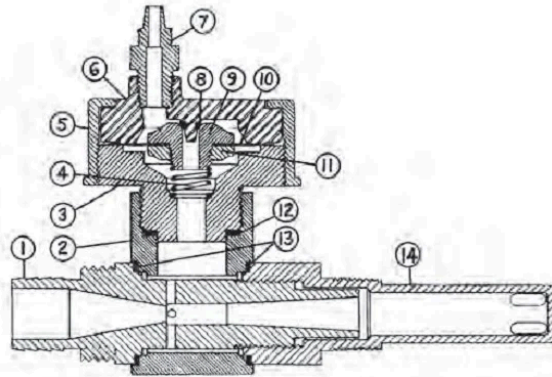

EJECTOR MODEL A-921A 100 PPD (2000 g/hr.)

Ejector Assembly Max. Capacity	A-921A 100 lbs./24hrs. (2000 g/hr)		
Ref. No.	Part No.	Quantity	Description
1	E-230 (3A, 4A, 5A) E-234 (17A)	1	Nozzle
2	E-210	1	Ejector Body
3	E-307	1	Outlet Body
4	E-310	1	Spring
5	E-301	1	Clamping Ring
6	E-302	1	Inlet Body
7	Z-250 (3/8" OD)	1	Tube Fitting
8	SA-302	1	Check Valve Seal
9	E-303	1	Diaphragm Bolt
10	E-304	1	Diaphragm
11	E-305	1	Diaphragm Nut
12	G-203	1	Seat Gasket
13	G-204	2	Body Gasket
14	E-240	1	Diffuser/Nozzle Retainer

NOTE: Include Ammoniator Serial Number and Capacity and Size (OD) of Vacuum Tubing Being Used.

DRAWING NO. A-930 High/Low Pressure Ejector Assembly (Optional)

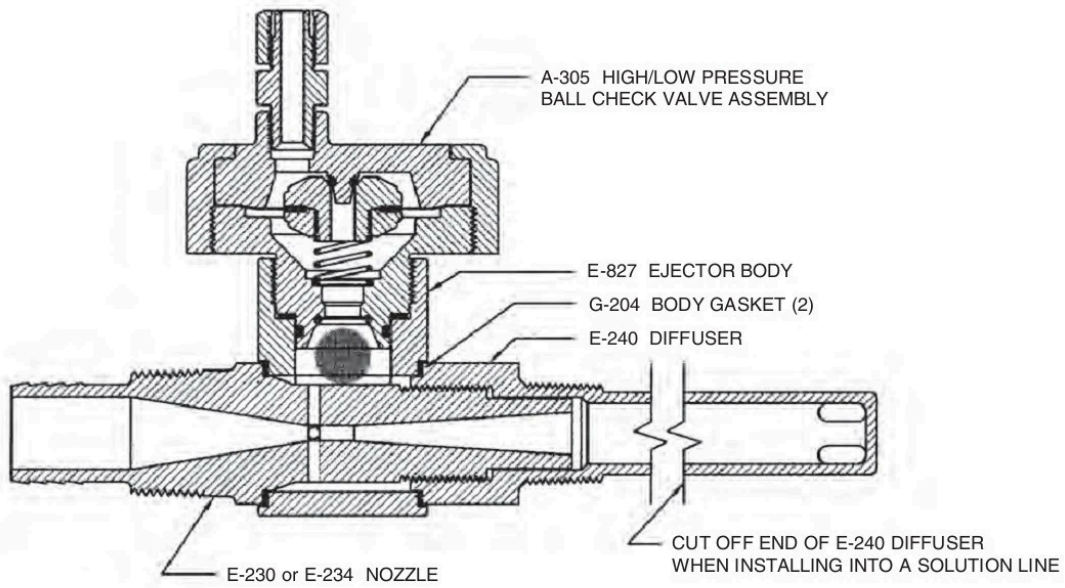

**A-305 HIGH/LOW PRESSURE BALL CHECK VALVE ASSEMBLY
100 PPD (2000 GM/HR) MAXIMUM**

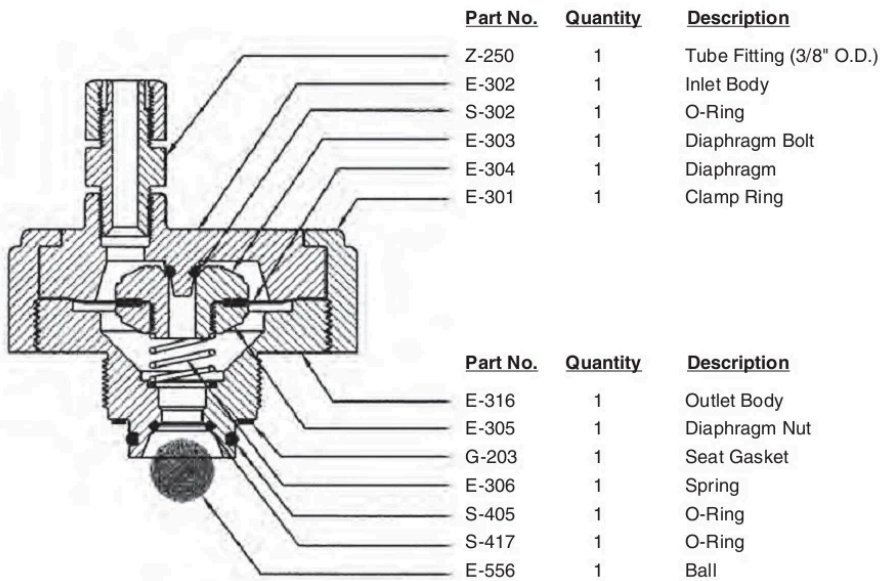

DRAWING NO. A-950/A-949 Ejector / Dual Check Valve Assembly (Optional)
Chlorine Service Only
Max Capacity: Up to 500 PPD (10KG/HR)

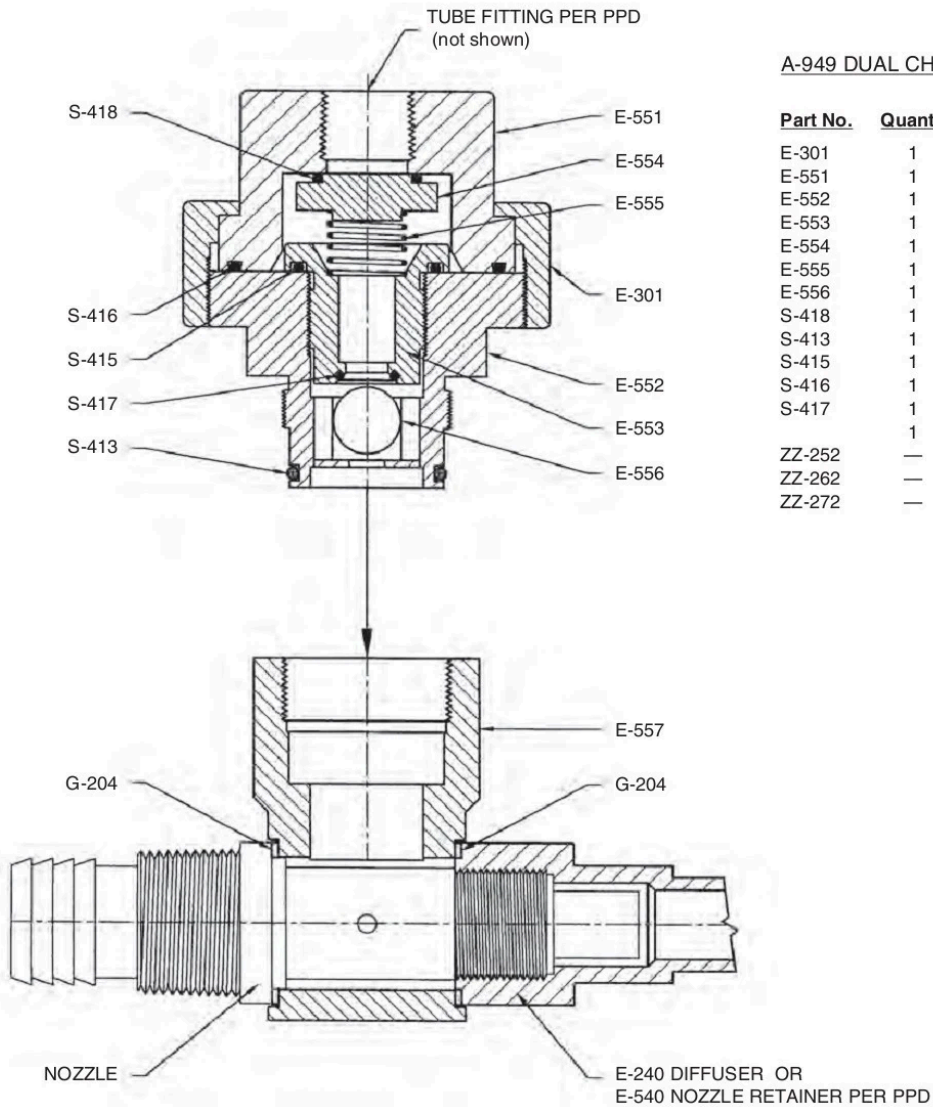

A-949 DUAL CHECK VALVE ASSEMBLY

Part No.	Quantity	Description
E-301	1	Clamp Ring
E-551	1	Top Body
E-552	1	Bottom Body
E-553	1	Spring/Ball Retainer
E-554	1	Poppet
E-555	1	Spring
E-556	1	Ball
S-418	1	O-Ring
S-413	1	O-Ring
S-415	1	O-Ring
S-416	1	O-Ring
S-417	1	O-Ring
	1	Tube Fitting Per PPD
ZZ-252	—	3/8" OD Tube (to 100 PPD)
ZZ-262	—	1/2" OD Tube (250 PPD)
ZZ-272	—	5/8" OD Tube (500 PPD)

A-950 EJECTOR ASSEMBLY

Part No.	Quantity	Description
A-949	1	Dual Check Valve Assembly
E-557	1	Ejector Body
—	1	Nozzle - Sized Per PPD
—	1	Diffuser or Nozzle Retainer Per PPD
E-240	—	Diffuser (1.5 to 250 PPD)
E-540	—	Nozzle Retainer (500 PPD-50X Nozzle Only)
G-204	2	Gasket

DRAWING NO. A-2920/A-2922 Ejector Assembly — Chlorine Service Only
1000 PPD (20KG/HR) / 2000 PPD (40KG/HR)

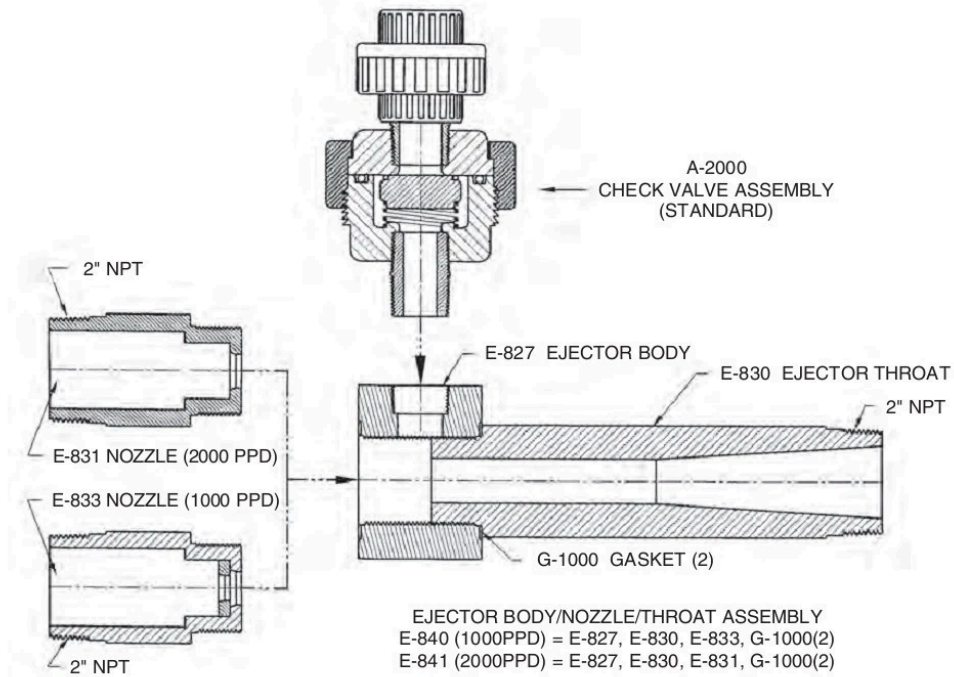

DRAWING NO. A-2000 Check Valve Assembly — Chlorine Service Only
1000 PPD (20KG/HR) / 2000 PPD (40KG/HR)

A-2000 CHECK VALVE ASSEMBLY (STANDARD)

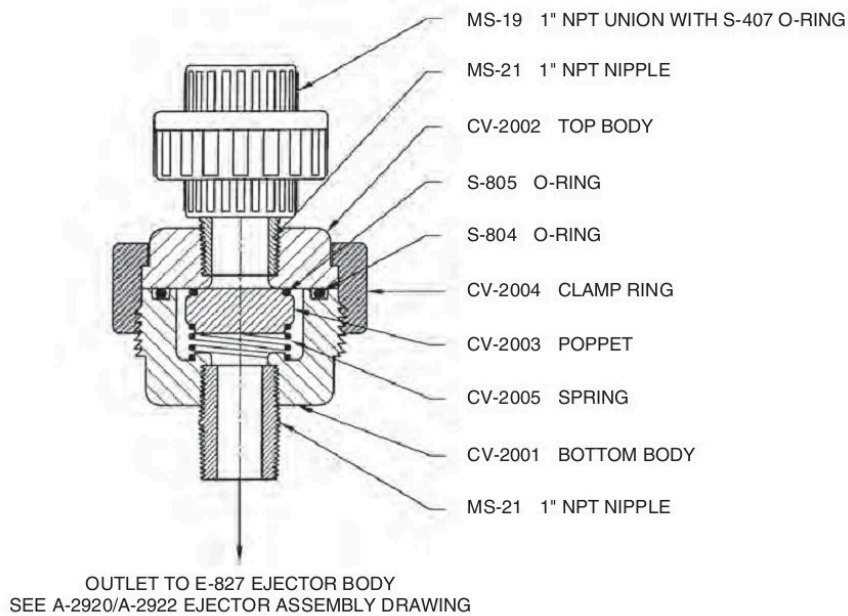

Application Bulletin No. 1002

IMPORTANT NOTE: The following nozzle selection charts are for CHLORINATORS, SULPHONATORS and AMMONIATORS. When the ejectors are used on gases other than chlorine, beside material changes, a factor must be used to determine the equivalent chlorine capacity before using these charts.

Since the density of Sulfur Dioxide is essentially the same as chlorine, the nozzle sizing is the same and the charts can be used as printed.

For ammonia, multiply the capacity by 0.5 and size using the appropriate chlorinator chart.

HYDRAULIC CONSIDERATIONS

In order to achieve proper operation of the chlorinator, it is essential that you carefully identify and consider the various factors related to installation of the ejector. These hydraulic conditions (listed below) must be known in order to create sufficient vacuum to feed the desired amount of chlorine gas.

1. BACKPRESSURE

- Backpressure is simply the total water pressure measured immediately downstream of the ejector outlet. In Figure 1, if a pressure gauge were to be installed between the ejector outlet and the water main, it would read the backpressure.
- Beware of "ASSUMING" the backpressure to be the same as the water system pressure. Pressures throughout a water system can vary greatly.
- Always consider the *maximum* backpressure.

2. SUPPLY PRESSURE

- Supply pressure is the water pressure measured at the inlet of the ejector.
- A pressure gauge should be permanently installed in the ejector supply line, as close as possible to the ejector inlet.
- The required ejector supply pressure can be obtained from any source, as long as the minimum pressure and water flow are available (See Ejector Nozzle Requirements charts on the following pages). A booster pump must be added if necessary.

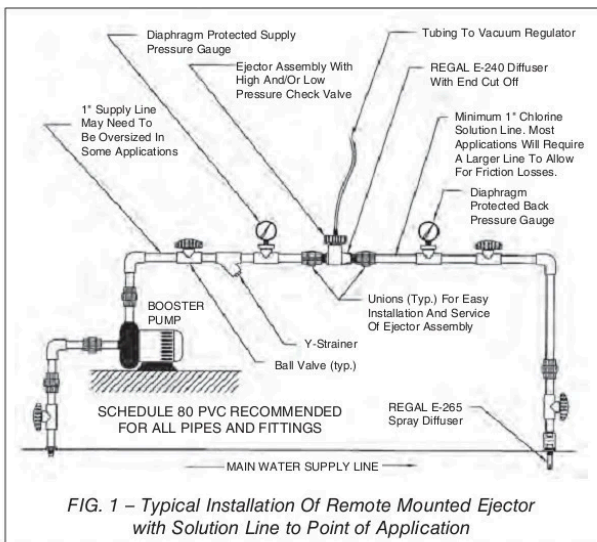

3. DIFFERENTIAL PRESSURE

- This is the difference in pressures between the ejector supply pressure and the backpressure. This is often referred to as the pressure "drop" across the ejector.
- The differential pressure required to properly operate the chlorinator at a particular chlorine feed rate, will vary as the backpressure increases or decreases. Generally, as backpressure increases, the required differential pressure will increase.
- Water "booster" pumps are commonly used to create a differential pressure by raising the system pressure and then passing the higher pressure water through the ejector and back into the system (See Fig. 1). However, a booster pump is not always necessary to obtain the required differential pressure.

4. FRICTION LOSS

- Friction loss is a term used to describe RESISTANCE to water flowing through pipes, valves and fittings. In general, smaller pipe diameters, longer pipe length, and increased numbers of valves and fittings, will create more friction loss.
- In ejector installations, it is important to determine if any significant friction loss can occur:
EJECTOR SUPPLY - friction loss on the water supply side of the ejector will result in *lower* water pressure available.
BACKPRESSURE - friction loss between the ejector outlet and the point of chlorine solution injection, will create *higher* backpressure.
- Friction loss can be calculated from information found in standard books, such as Cameron's Hydraulic Data, or from tables published by pipe and fitting suppliers.

HOW TO USE THE EJECTOR NOZZLE REQUIREMENTS CHART

The charts on the following pages represent minimum values (Ejector Supply Pressures and Water Flow Rates through the ejector) necessary to operate a REGAL Series 200 Gas Chlorinator at each maximum metering tube (rotameter) capacity, against specific backpressures.

THE NOZZLE (or Venturi)

The nozzle in your REGAL ejector is chosen to give you the widest range of serviceability in most standard applications at the maximum chlorine gas feed rate on the metering tube. Chlorinators Inc. has designed several different sizes of nozzles. Figure 2, below, shows the location of the stamped size designation:

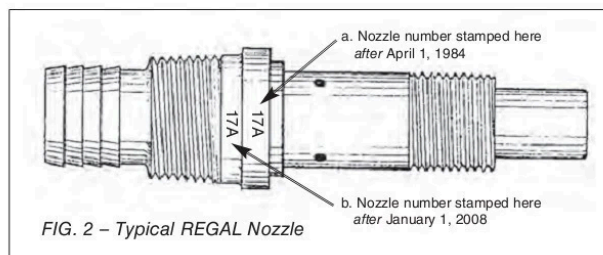

STANDARD NOZZLE

The "Standard Nozzle" shown on each chart is the one which would be supplied with a REGAL Series 200 Gas Chlorinator based on the maximum capacity of the system. (EXAMPLE: a chlorinator with a maximum capacity of 25 PPD (500 gr./hr.) will normally be supplied with a size 5A nozzle).

USING THE CHARTS

To find out what hydraulic conditions you need to operate the chlorinator, follow these steps:

1. a. Determine the maximum required feed rate for the system to be treated.
- b. Refer to the Maximum Chlorine Feed Rate Charts on the following pages. Select the chart for the feed rate that is next higher than your system's required maximum. Ideally, your system's requirement should be about 50% to 75% of the chlorinator's maximum feed rate. Do not select a chart for a feed rate that exactly matches your system's requirement. Use the next higher chart. With this approach, the metering ball should be in the upper half of the metering tube for most adjustments that you might have to make.

IMPORTANT NOTE: You may not need to feed the maximum rate of gas flow on the metering tube, but you should still use the values given for that maximum capacity.

2. Using the column headed "EJECTOR BACKPRESSURE" find the maximum backpressure for your system (see definition of "backpressure" on previous page) in English units of PSIG or Metric units of (kg/cm²).
3. Follow the backpressure line across to the first column under the heading "STANDARD NOZZLE," marked with an (*).
4. Read the *required* minimum "EJECTOR SUPPLY PRESSURE" in PSIG or (kg/cm²) and immediately to the right of EJECTOR SUPPLY PRESSURE, read the *required minimum* "WATER FLOW RATE" in U.S. GPM or (liters/sec).
5. The difference between the Ejector Supply Pressure and the Backpressure is the required DIFFERENTIAL PRESSURE (see previous page).

Example: Using a water treatment system as in Fig. 1, with a pressure in the water main at the ejector of 60 PSIG maximum (4.21 kg/cm²) and a desired chlorine feed rate of 18 PPD.

- a. Use the 25 PPD chart.
- b. Under "EJECTOR BACKPRESSURE" locate 60 PSI (4.21 kg/cm²) and read across to the "STANDARD NOZZLE No. 5A*" column.

- c. The EJECTOR SUPPLY PRESSURE must be at least 94 PSI (6.61 kg/cm²) and the nozzle will require at least 10.8 U.S. GPM (0.68 l/sec.) WATER FLOW.
- d. Therefore, the DIFFERENTIAL PRESSURE necessary is 34 PSI (2.40 kg/cm²) or 94 (6.61) minus 60 (4.21).
- e. In this example, a booster pump is used to take water from the system and raise (boost) the pressure at *least* 34 PSI (2.40 kg/cm²).

NOTE: However, if another, independent water source were available that could provide the ejector with at least 94 PSI (6.61 kg/cm²) pressure at 10.8 U.S. GPM (0.68 l/sec.) that water source could be used to operate the ejector without a booster pump.

USING A NON-STANDARD NOZZLE

It may be necessary to use a nozzle which is not "standard" for the capacity of the chlorinator. This is usually caused when:

1. A REGAL Gas Chlorinator is replacing an older, existing gas chlorinator and available hydraulic conditions do not match the specifications for the "standard" REGAL nozzle.
2. Or, an existing booster pump is not capable of providing required water flow and/or pressure.
3. Or, the water supply and/or solution pipe may be too small compared to the flow rate for the standard nozzle. A different nozzle may require a lesser flow for a given capacity and therefore produce less friction.

In these cases, use the chart appropriate for the Maximum Chlorine Feed Rate. Find the EJECTOR BACKPRESSURE, and look across the nozzle columns to find EJECTOR SUPPLY PRESSURE and WATER FLOW RATE which the system can meet. Use the nozzle shown at the top of that column.

NOTE: If it does not appear that your application can meet the requirements shown, contact Chlorinators Incorporated.

REGAL EJECTOR NOZZLE REQUIREMENTS

Maximum Chlorine Feed Rate — 4 PPD (75 Grams/Hr.) See Note.

NOZZLE		Standard Nozzle No. 4A*		No. 3A		No. 5A		No. 17A	
EJECTOR BACKPRESSURE		REQUIRED Ejector Supply Pressure and Water Flow Rate		REQUIRED Ejector Supply Pressure and Water Flow Rate		REQUIRED Ejector Supply Pressure and Water Flow Rate		REQUIRED Ejector Supply Pressure and Water Flow Rate	
PSIG	kg/cm ²	PSIG @ GPM	kg/cm ² @ l/sec.	PSIG @ GPM	kg/cm ² @ l/sec.	PSIG @ GPM	kg/cm ² @ l/sec.	PSIG @ GPM	kg/cm ² @ l/sec.
0	0	7 @ 1.5	0.49 @ 0.09	5 @ 1.0	0.35 @ 0.06	7 @ 2.1	0.49 @ 0.13	6 @ 2.6	0.42 @ 0.16
10	0.70	18 @ 2.7	1.27 @ 0.17	20 @ 2.0	1.41 @ 0.13	18 @ 4.0	1.27 @ 0.25	19 @ 7.0	1.34 @ 0.44
20	1.40	33 @ 3.9	2.32 @ 0.25	37 @ 2.6	2.60 @ 0.16	33 @ 5.6	2.32 @ 0.35	35 @ 10.5	2.46 @ 0.66
30	2.10	47 @ 4.9	3.30 @ 0.31	49 @ 3.2	3.44 @ 0.20	46 @ 7.3	3.23 @ 0.46	55 @ 12.6	3.87 @ 0.79
40	2.81	64 @ 5.6	4.50 @ 0.35	66 @ 3.7	4.64 @ 0.23	63 @ 8.7	4.43 @ 0.55	74 @ 14.7	5.20 @ 0.93
50	3.51	81 @ 6.3	5.69 @ 0.40	81 @ 4.5	5.69 @ 0.28	77 @ 9.6	5.41 @ 0.61	90 @ 16.2	6.33 @ 1.02
60	4.21	96 @ 7.2	6.75 @ 0.45	97 @ 5.3	6.82 @ 0.33	91 @ 11.0	6.40 @ 0.69	104 @ 17.3	7.31 @ 1.09
70	4.92	109 @ 8.3	7.66 @ 0.52	111 @ 5.7	7.80 @ 0.36	108 @ 11.8	7.59 @ 0.74	122 @ 19.5	8.58 @ 1.23
80	5.62	126 @ 8.9	8.86 @ 0.56	125 @ 6.2	8.79 @ 0.39	122 @ 12.6	8.58 @ 0.79	137 @ 20.7	9.63 @ 1.31
90	6.32	140 @ 9.4	9.84 @ 0.59	139 @ 6.5	9.77 @ 0.41	137 @ 13.7	9.63 @ 0.86	155 @ 21.8	10.90 @ 1.38
100	7.03	154 @ 9.9	10.83 @ 0.62	151 @ 6.7	10.62 @ 0.42	150 @ 14.2	10.55 @ 0.90	173 @ 23.0	12.16 @ 1.45
110	7.73	173 @ 10.3	12.16 @ 0.65	166 @ 6.9	11.67 @ 0.44	168 @ 14.9	11.81 @ 0.94	190 @ 24.0	13.36 @ 1.51
120	8.44	188 @ 10.8	13.22 @ 0.68	182 @ 7.2	12.97 @ 0.45	184 @ 15.5	12.94 @ 0.98	209 @ 25.0	14.69 @ 1.58
130	9.14	204 @ 11.0	14.34 @ 0.69	196 @ 7.5	13.78 @ 0.47	199 @ 16.2	13.99 @ 1.02	228 @ 25.6	16.03 @ 1.61
140	9.84	220 @ 11.6	15.47 @ 0.73	211 @ 7.8	14.83 @ 0.49	213 @ 17.0	14.97 @ 1.07	245 @ 26.0	17.22 @ 1.64
150	10.55	235 @ 11.8	16.52 @ 0.74	225 @ 8.1	15.82 @ 0.51	220 @ 17.5	15.47 @ 1.10	263 @ 27.4	18.49 @ 1.73
160	11.25	245 @ 12.1	17.22 @ 0.76	—	—	242 @ 18.4	17.01 @ 1.16	284 @ 28.8	19.97 @ 1.82

*Standard Nozzle Supplied with Chlorinator for Indicated Maximum Feed Rate. NOTE: GPM is U.S. Gallons. Metric is liters per sec. (l/sec.)

Maximum Chlorine Feed Rate — 10 PPD (200 Grams/Hr.) See Note.

NOZZLE		Standard Nozzle No. 4A*		No. 3A		No. 5A		No. 17A	
EJECTOR BACKPRESSURE		REQUIRED Ejector Supply Pressure and Water Flow Rate		REQUIRED Ejector Supply Pressure and Water Flow Rate		REQUIRED Ejector Supply Pressure and Water Flow Rate		REQUIRED Ejector Supply Pressure and Water Flow Rate	
PSIG	kg/cm ²	PSIG @ GPM	kg/cm ² @ l/sec.	PSIG @ GPM	kg/cm ² @ l/sec.	PSIG @ GPM	kg/cm ² @ l/sec.	PSIG @ GPM	kg/cm ² @ l/sec.
0	0	10 @ 1.7	0.70 @ 0.11	10 @ 1.4	0.70 @ 0.09	9 @ 2.3	0.63 @ 0.15	8 @ 3.0	0.56 @ 0.19
10	0.70	24 @ 3.3	1.69 @ 0.21	25 @ 2.3	1.76 @ 0.15	23 @ 4.5	1.62 @ 0.28	23 @ 7.3	1.62 @ 0.46
20	1.40	35 @ 4.3	2.46 @ 0.27	41 @ 2.9	2.88 @ 0.18	34 @ 6.2	2.39 @ 0.39	37 @ 10.6	2.60 @ 0.67
30	2.10	50 @ 5.0	3.52 @ 0.32	55 @ 3.5	3.87 @ 0.22	49 @ 7.7	3.44 @ 0.49	57 @ 12.8	4.01 @ 0.81
40	2.81	64 @ 5.7	4.50 @ 0.36	68 @ 3.9	4.78 @ 0.25	64 @ 8.8	4.50 @ 0.56	76 @ 14.9	5.34 @ 0.94
50	3.51	81 @ 6.6	5.69 @ 0.42	84 @ 4.3	5.91 @ 0.27	78 @ 9.7	5.48 @ 0.61	91 @ 16.4	6.40 @ 1.03
60	4.21	96 @ 7.2	6.75 @ 0.45	97 @ 4.6	6.82 @ 0.29	93 @ 10.8	6.54 @ 0.68	106 @ 17.9	7.45 @ 1.13
70	4.92	110 @ 8.0	7.73 @ 0.50	111 @ 5.0	7.80 @ 0.32	110 @ 11.7	7.73 @ 0.74	124 @ 19.7	8.72 @ 1.24
80	5.62	125 @ 8.6	8.79 @ 0.54	125 @ 5.8	8.79 @ 0.37	122 @ 12.7	8.58 @ 0.80	139 @ 20.9	9.77 @ 1.32
90	6.32	139 @ 9.2	9.77 @ 0.58	139 @ 6.4	9.77 @ 0.40	138 @ 13.7	9.70 @ 0.86	157 @ 22.0	11.04 @ 1.39
100	7.03	154 @ 9.7	10.83 @ 0.61	153 @ 6.7	10.76 @ 0.42	151 @ 14.3	10.62 @ 0.90	174 @ 23.2	12.23 @ 1.46
110	7.73	169 @ 10.2	11.88 @ 0.64	170 @ 7.1	11.95 @ 0.45	168 @ 14.9	11.81 @ 0.94	192 @ 24.2	13.50 @ 1.53
120	8.44	183 @ 10.6	12.86 @ 0.67	183 @ 7.4	12.86 @ 0.47	184 @ 15.9	12.94 @ 1.00	213 @ 25.2	14.97 @ 1.59
130	9.14	199 @ 11.3	13.99 @ 0.71	199 @ 7.7	13.99 @ 0.49	199 @ 16.3	13.99 @ 1.03	232 @ 26.2	16.31 @ 1.65
140	9.84	214 @ 11.5	15.04 @ 0.73	212 @ 7.8	14.90 @ 0.50	212 @ 17.2	14.90 @ 1.08	248 @ 27.1	17.43 @ 1.71
150	10.55	232 @ 11.9	16.31 @ 0.75	230 @ 8.0	16.17 @ 0.51	228 @ 17.5	16.03 @ 1.10	270 @ 28.3	18.98 @ 1.79
160	11.25	245 @ 12.4	17.22 @ 0.78	242 @ 8.3	17.01 @ 0.52	241 @ 18.2	16.94 @ 1.15	288 @ 29.1	20.25 @ 1.84

Maximum Chlorine Feed Rate — 25 PPD (500 Grams/Hr.) See Note.

NOZZLE		Standard Nozzle No. 5A*		No. 3A		No. 4A		No. 17A	
EJECTOR BACKPRESSURE		REQUIRED Ejector Supply Pressure and Water Flow Rate		REQUIRED Ejector Supply Pressure and Water Flow Rate		REQUIRED Ejector Supply Pressure and Water Flow Rate		REQUIRED Ejector Supply Pressure and Water Flow Rate	
PSIG	kg/cm ²	PSIG @ GPM	kg/cm ² @ l/sec.	PSIG @ GPM	kg/cm ² @ l/sec.	PSIG @ GPM	kg/cm ² @ l/sec.	PSIG @ GPM	kg/cm ² @ l/sec.
0	0	14 @ 3.1	0.98 @ 0.20	16 @ 1.7	1.12 @ 0.11	16 @ 2.4	1.12 @ 0.15	11 @ 3.4	0.77 @ 0.21
10	0.70	28 @ 5.4	1.97 @ 0.34	35 @ 2.7	2.46 @ 0.17	35 @ 3.3	2.46 @ 0.21	26 @ 7.5	1.83 @ 0.47
20	1.40	47 @ 7.5	3.30 @ 0.47	55 @ 3.5	3.87 @ 0.22	50 @ 4.9	3.52 @ 0.31	44 @ 10.8	3.09 @ 0.68
30	2.10	62 @ 8.6	4.36 @ 0.54	75 @ 4.0	5.27 @ 0.25	66 @ 5.9	4.64 @ 0.37	59 @ 12.9	4.15 @ 0.81
40	2.81	71 @ 9.2	4.99 @ 0.58	94 @ 4.5	6.61 @ 0.28	78 @ 6.5	5.48 @ 0.41	78 @ 15.1	5.48 @ 0.95
50	3.51	81 @ 9.9	5.69 @ 0.62	106 @ 4.9	7.45 @ 0.31	94 @ 7.1	6.61 @ 0.45	93 @ 16.8	6.54 @ 1.06
60	4.21	94 @ 10.8	6.61 @ 0.68	117 @ 5.2	8.23 @ 0.33	107 @ 7.6	7.52 @ 0.48	107 @ 18.2	7.52 @ 1.15
70	4.92	109 @ 12.1	7.66 @ 0.76	131 @ 5.5	9.21 @ 0.35	117 @ 8.1	8.23 @ 0.51	126 @ 20.0	8.86 @ 1.26
80	5.62	122 @ 12.7	8.58 @ 0.80	143 @ 5.8	10.05 @ 0.37	130 @ 8.6	9.14 @ 0.54	142 @ 21.0	9.98 @ 1.32
90	6.32	139 @ 13.8	9.77 @ 0.87	156 @ 6.0	10.97 @ 0.38	142 @ 9.2	9.98 @ 0.58	161 @ 22.2	11.32 @ 1.40
100	7.03	153 @ 14.4	10.76 @ 0.91	169 @ 6.3	11.88 @ 0.40	158 @ 9.8	11.11 @ 0.62	179 @ 23.5	12.58 @ 1.48
110	7.73	168 @ 15.0	11.81 @ 0.95	179 @ 6.5	12.58 @ 0.41	174 @ 10.3	12.23 @ 0.65	195 @ 24.5	13.71 @ 1.55
120	8.44	183 @ 15.9	12.86 @ 1.00	191 @ 6.6	13.43 @ 0.42	189 @ 10.8	13.29 @ 0.68	215 @ 25.5	15.11 @ 1.61
130	9.14	199 @ 16.3	13.99 @ 1.03	204 @ 6.9	14.34 @ 0.44	204 @ 11.3	14.34 @ 0.71	235 @ 26.5	16.52 @ 1.67
140	9.84	214 @ 17.0	15.04 @ 1.07	220 @ 7.1	15.47 @ 0.45	220 @ 11.6	15.47 @ 0.73	252 @ 27.3	17.72 @ 1.72
150	10.55	220 @ 17.5	15.47 @ 1.10	235 @ 7.4	16.52 @ 0.47	235 @ 11.9	16.52 @ 0.75	273 @ 28.5	19.19 @ 1.80
160	11.25	233 @ 18.4	16.38 @ 1.16	256 @ 7.7	18.00 @ 0.49	250 @ 12.4	17.58 @ 0.78	291 @ 29.4	20.46 @ 1.85

Maximum Chlorine Feed Rate — 50 PPD (900 Grams/Hr.) See Note.

NOZZLE		Standard Nozzle No. 17A*		No. 3A		No. 4A		No. 5A	
EJECTOR BACKPRESSURE		REQUIRED Ejector Supply Pressure and Water Flow Rate		REQUIRED Ejector Supply Pressure and Water Flow Rate		REQUIRED Ejector Supply Pressure and Water Flow Rate		REQUIRED Ejector Supply Pressure and Water Flow Rate	
PSIG	kg/cm ²	PSIG @ GPM	kg/cm ² @ l/sec.	PSIG @ GPM	kg/cm ² @ l/sec.	PSIG @ GPM	kg/cm ² @ l/sec.	PSIG @ GPM	kg/cm ² @ l/sec.
0	0	15 @ 5.0	1.05 @ 0.32	23 @ 2.2	1.62 @ 0.14	26 @ 3.4	1.83 @ 0.21	17 @ 3.8	1.20 @ 0.24
10	0.70	29 @ 7.8	2.04 @ 0.49	56 @ 3.5	3.94 @ 0.22	57 @ 5.5	4.01 @ 0.35	38 @ 6.6	2.67 @ 0.42
20	1.40	45 @ 11.0	3.16 @ 0.69	85 @ 4.3	5.98 @ 0.27	86 @ 6.9	6.05 @ 0.44	63 @ 8.6	4.43 @ 0.54
30	2.10	61 @ 13.0	4.29 @ 0.82	108 @ 4.8	7.59 @ 0.30	111 @ 7.8	7.80 @ 0.49	83 @ 10.0	5.83 @ 0.63
40	2.81	80 @ 15.3	5.62 @ 0.97	126 @ 5.4	8.86 @ 0.34	133 @ 8.9	9.35 @ 0.56	101 @ 11.2	7.10 @ 0.71
50	3.51	97 @ 17.0	6.82 @ 1.07	146 @ 5.8	10.26 @ 0.37	147 @ 9.5	10.33 @ 0.60	112 @ 12.5	7.87 @ 0.79
60	4.21	109 @ 18.5	7.66 @ 1.17	167 @ 6.2	11.74 @ 0.39	170 @ 10.0	11.95 @ 0.63	122 @ 12.8	8.58 @ 0.81
70	4.92	129 @ 20.3	9.07 @ 1.28	189 @ 6.5	13.29 @ 0.41	187 @ 10.3	13.15 @ 0.65	136 @ 13.6	9.56 @ 0.86
80	5.62	144 @ 21.3	10.12 @ 1.34	208 @ 6.8	14.62 @ 0.43	199 @ 11.0	13.99 @ 0.69	152 @ 14.3	10.69 @ 0.90
90	6.32	164 @ 22.5	11.53 @ 1.42	225 @ 7.2	15.82 @ 0.45	213 @ 11.4	14.97 @ 0.72	166 @ 15.0	11.67 @ 0.95
100	7.03	182 @ 23.7	12.79 @ 1.49	240 @ 7.6	16.87 @ 0.48	228 @ 11.6	16.03 @ 0.73	173 @ 15.3	12.16 @ 0.97
110	7.73	199 @ 24.7	13.99 @ 1.56	261 @ 7.9	18.35 @ 0.50	232 @ 12.0	16.31 @ 0.76	183 @ 15.9	12.86 @ 1.00
120	8.44	218 @ 25.9	15.33 @ 1.63	272 @ 8.3	19.12 @ 0.52	255 @ 12.5	17.93 @ 0.79	191 @ 16.1	13.43 @ 1.02
130	9.14	238 @ 26.9	16.73 @ 1.70	293 @ 8.5	20.60 @ 0.54	265 @ 12.6	18.63 @ 0.80	206 @ 16.7	14.48 @ 1.05
140	9.84	256 @ 27.7	18.00 @ 1.75	—	—	272 @ 12.8	19.12 @ 0.81	221 @ 17.4	15.54 @ 1.10
150	10.55	277 @ 28.9	19.47 @ 1.82	—	—	285 @ 13.1	20.04 @ 0.83	233 @ 18.0	16.38 @ 1.14
160	11.25	295 @ 29.8	20.74 @ 1.88	—	—	—	—	248 @ 18.5	17.43 @ 1.17

*Standard Nozzle Supplied with Chlorinator for Indicated Maximum Feed Rate. NOTE: GPM is U.S. Gallons. Metric is liters per sec. (l/sec.)

Maximum Chlorine Feed Rate — 100 PPD (2000 Grams/Hr.) See Note.

NOZZLE		Standard Nozzle No. 17A*		No. 3A		No. 4A		No. 5A		No. 18A	
EJECTOR BACK-PRESSURE		REQUIRED Ejector Supply Pressure and Water Flow Rate		REQUIRED Ejector Supply Pressure and Water Flow Rate		REQUIRED Ejector Supply Pressure and Water Flow Rate		REQUIRED Ejector Supply Pressure and Water Flow Rate		REQUIRED Ejector Supply Pressure and Water Flow Rate	
PSIG	kg/cm ²	PSIG @ GPM	kg/cm ² @ l/sec.	PSIG @ GPM	kg/cm ² @ l/sec.	PSIG @ GPM	kg/cm ² @ l/sec.	PSIG @ GPM	kg/cm ² @ l/sec.	PSIG @ GPM	kg/cm ² @ l/sec.
0	0	23 @ 7.4	1.62 @ 0.47	59 @ 3.6	4.15 @ 0.23	50 @ 5.1	3.52 @ 0.32	27 @ 5.1	1.90 @ 0.32	19 @ 9.1	1.34 @ 0.57
10	0.70	43 @ 10.0	3.02 @ 0.63	100 @ 4.7	7.03 @ 0.30	108 @ 7.8	7.59 @ 0.49	57 @ 8.4	4.01 @ 0.53	35 @ 11.2	2.46 @ 0.71
20	1.40	57 @ 12.1	4.01 @ 0.76	148 @ 5.8	10.40 @ 0.37	165 @ 9.7	11.60 @ 0.61	93 @ 10.8	6.54 @ 0.68	50 @ 13.8	3.52 @ 0.87
30	2.10	70 @ 13.5	4.92 @ 0.85	188 @ 6.5	13.22 @ 0.41	213 @ 11.3	14.97 @ 0.71	119 @ 12.8	8.37 @ 0.81	64 @ 15.7	4.50 @ 0.99
40	2.81	84 @ 15.5	5.91 @ 0.98	242 @ 7.3	17.01 @ 0.46	251 @ 12.4	17.65 @ 0.78	143 @ 14.0	10.05 @ 0.88	76 @ 17.2	5.34 @ 1.08
50	3.51	101 @ 17.3	7.10 @ 1.09	268 @ 7.9	18.84 @ 0.50	285 @ 13.0	20.04 @ 0.82	169 @ 15.1	11.88 @ 0.95	90 @ 19.6	6.33 @ 1.24
60	4.21	113 @ 18.9	7.94 @ 1.19	—	—	—	—	188 @ 16.1	13.22 @ 1.02	106 @ 21.3	7.45 @ 1.34
70	4.92	132 @ 20.6	9.28 @ 1.30	—	—	—	—	202 @ 16.7	14.20 @ 1.05	120 @ 23.2	8.44 @ 1.46
80	5.62	146 @ 21.8	10.26 @ 1.38	—	—	—	—	220 @ 17.4	15.47 @ 1.10	137 @ 24.7	9.63 @ 1.56
90	6.32	167 @ 23.0	11.74 @ 1.45	—	—	—	—	236 @ 18.2	16.59 @ 1.15	153 @ 26.4	10.76 @ 1.67
100	7.03	185 @ 24.0	13.01 @ 1.51	—	—	—	—	261 @ 19.3	18.35 @ 1.22	168 @ 27.6	11.81 @ 1.74
110	7.73	202 @ 25.0	14.20 @ 1.58	—	—	—	—	279 @ 19.9	19.61 @ 1.26	183 @ 28.7	12.86 @ 1.81
120	8.44	220 @ 26.1	15.47 @ 1.65	—	—	—	—	295 @ 20.5	20.74 @ 1.29	202 @ 30.1	14.20 @ 1.90
130	9.14	241 @ 27.1	16.94 @ 1.71	—	—	—	—	—	—	218 @ 31.3	15.33 @ 1.97
140	9.84	260 @ 28.2	18.28 @ 1.78	—	—	—	—	—	—	235 @ 32.5	16.52 @ 2.05
150	10.55	281 @ 29.0	19.75 @ 1.83	—	—	—	—	—	—	251 @ 33.4	17.65 @ 2.11
160	11.25	298 @ 29.9	20.95 @ 1.89	—	—	—	—	—	—	272 @ 33.7	19.12 @ 2.13

Maximum Chlorine Feed Rate — 200 PPD (4000 Grams/Hr.) See Note.

Maximum Chlorine Feed Rate — 250 PPD (4900 Grams/Hr.) See Note.

NOZZLE		Standard Nozzle No. 18A*		No. 17A		No. 50X		Standard Nozzle No. 18A*		No. 50X	
EJECTOR BACK-PRESSURE		REQUIRED Ejector Supply Pressure and Water Flow Rate		REQUIRED Ejector Supply Pressure and Water Flow Rate		REQUIRED Ejector Supply Pressure and Water Flow Rate		REQUIRED Ejector Supply Pressure and Water Flow Rate		REQUIRED Ejector Supply Pressure and Water Flow Rate	
PSIG	kg/cm ²	PSIG @ GPM	kg/cm ² @ l/sec.	PSIG @ GPM	kg/cm ² @ l/sec.	PSIG @ GPM	kg/cm ² @ l/sec.	PSIG @ GPM	kg/cm ² @ l/sec.	PSIG @ GPM	kg/cm ² @ l/sec.
0	0	26 @ 9.3	1.83 @ 0.59	27 @ 7.8	1.90 @ 0.49	22 @ 8.6	1.55 @ 0.54	50 @ 13.4	3.52 @ 0.85	27 @ 11.5	1.90 @ 0.73
10	0.70	51 @ 13.8	3.59 @ 0.87	58 @ 12.4	4.08 @ 0.78	34 @ 12.7	2.39 @ 0.80	70 @ 15.9	4.92 @ 1.00	37 @ 13.8	2.60 @ 0.87
20	1.40	67 @ 16.2	4.71 @ 1.02	80 @ 14.3	5.62 @ 0.90	47 @ 15.5	3.30 @ 0.98	92 @ 18.1	6.47 @ 1.14	49 @ 16.1	3.44 @ 1.02
30	2.10	83 @ 18.4	5.83 @ 1.16	96 @ 16.1	6.75 @ 1.02	67 @ 19.3	4.71 @ 1.22	103 @ 19.8	7.24 @ 1.25	68 @ 19.5	4.78 @ 1.23
40	2.81	97 @ 20.2	6.82 @ 0.27	107 @ 17.3	7.52 @ 1.09	88 @ 22.4	6.19 @ 1.41	118 @ 21.8	8.03 @ 1.38	89 @ 22.7	6.26 @ 1.43
50	3.51	110 @ 21.8	7.73 @ 1.38	123 @ 18.9	8.65 @ 1.19	109 @ 25.3	7.66 @ 1.60	130 @ 23.9	9.14 @ 1.51	109 @ 25.3	7.66 @ 1.60
60	4.21	124 @ 23.5	8.72 @ 1.48	138 @ 20.1	9.70 @ 1.27	130 @ 27.9	9.14 @ 1.76	143 @ 25.1	10.05 @ 1.58	130 @ 27.9	9.14 @ 1.76
70	4.92	135 @ 24.4	9.49 @ 1.54	147 @ 21.0	10.33 @ 1.32	148 @ 29.9	10.40 @ 1.89	158 @ 25.9	11.11 @ 1.63	148 @ 29.9	10.40 @ 1.89
80	5.62	147 @ 25.5	10.33 @ 1.61	163 @ 22.1	11.46 @ 1.39	169 @ 31.9	11.88 @ 2.01	172 @ 27.3	12.09 @ 1.72	169 @ 31.9	11.88 @ 2.01
90	6.32	160 @ 26.7	11.25 @ 1.68	176 @ 23.4	12.37 @ 1.48	192 @ 34.5	13.50 @ 2.18	183 @ 28.5	12.86 @ 1.80	192 @ 34.5	13.50 @ 2.18
100	7.03	173 @ 27.8	12.16 @ 1.75	193 @ 24.4	13.57 @ 1.54	210 @ 36.8	14.76 @ 2.32	195 @ 29.1	13.71 @ 1.84	210 @ 36.8	14.76 @ 2.32
110	7.73	190 @ 28.9	13.36 @ 1.82	209 @ 25.5	14.69 @ 1.61	228 @ 38.5	16.03 @ 2.43	211 @ 30.2	14.83 @ 1.91	228 @ 38.5	16.03 @ 2.43
120	8.44	207 @ 30.1	14.55 @ 1.90	228 @ 26.3	16.03 @ 1.66	—	—	214 @ 31.0	15.04 @ 1.96	—	—
130	9.14	222 @ 31.3	15.61 @ 1.97	245 @ 27.3	17.22 @ 1.72	—	—	238 @ 31.9	16.73 @ 2.01	—	—
140	9.84	239 @ 32.4	16.80 @ 2.04	267 @ 28.4	18.77 @ 1.79	—	—	253 @ 33.3	17.79 @ 2.10	—	—
150	10.55	255 @ 33.4	17.93 @ 2.11	288 @ 29.2	20.25 @ 1.84	—	—	272 @ 34.3	19.12 @ 2.16	—	—
160	11.25	275 @ 34.5	19.33 @ 2.18	306 @ 30.2	21.51 @ 1.91	—	—	288 @ 35.6	20.25 @ 2.25	—	—

Maximum Chlorine Feed Rate — 500 PPD (10 Kg./Hr.) See Note.

NOZZLE		Standard Nozzle No. 50X*	
EJECTOR BACK-PRESSURE		REQUIRED Ejector Supply Pressure and Water Flow Rate	
PSIG	kg/cm ²	PSIG @ GPM	kg/cm ² @ l/sec.
0	0	72 @ 20.7	5.06 @ 1.31
10	0.70	89 @ 23.1	6.26 @ 1.46
20	1.40	97 @ 24.1	6.82 @ 1.52
30	2.10	105 @ 25.2	7.38 @ 1.59
40	2.81	113 @ 26.3	7.94 @ 1.66
50	3.51	125 @ 27.3	8.79 @ 1.72
60	4.21	138 @ 29.0	9.70 @ 1.83
70	4.92	155 @ 31.5	10.90 @ 1.99
80	5.62	173 @ 32.2	12.16 @ 2.03
90	6.32	192 @ 34.5	13.50 @ 2.18
100	7.03	210 @ 36.8	14.76 @ 2.32
110	7.73	228 @ 38.5	16.03 @ 2.43

*Standard Nozzle Supplied with Chlorinator for Indicated Maximum Feed Rate. NOTE: GPM is U.S. Gallons. Metric is liters per sec. (l/sec.)

Maximum Chlorine Feed Rate — 4 PPD (75 Grams/Hr.) See Note.

NOZZLE		No. 13A		No. 14A		No. 15A		No. 16A	
EJECTOR BACKPRESSURE		REQUIRED Ejector Supply Pressure and Water Flow Rate		REQUIRED Ejector Supply Pressure and Water Flow Rate		REQUIRED Ejector Supply Pressure and Water Flow Rate		REQUIRED Ejector Supply Pressure and Water Flow Rate	
PSIG	kg/cm ²	PSIG @ GPM	kg/cm ² @ l/sec.	PSIG @ GPM	kg/cm ² @ l/sec.	PSIG @ GPM	kg/cm ² @ l/sec.	PSIG @ GPM	kg/cm ² @ l/sec.
0	0	5 @ 1.0	.352 @ .063	4 @ 1.3	.281 @ .098	2 @ 1.9	0.14 @ .120	3 @ 2.2	.211 @ .139
10	0.70	22 @ 1.9	1.55 @ .120	18 @ 2.8	1.27 @ .212	24 @ 4.0	1.69 @ .252	20 @ 4.7	1.41 @ .297
20	1.40	32 @ 2.5	2.25 @ .158	31 @ 3.3	2.18 @ .250	41 @ 4.9	2.88 @ .309	36 @ 6.2	2.53 @ .391
30	2.10	46 @ 3.0	3.23 @ .189	47 @ 3.9	3.30 @ .295	58 @ 5.7	4.08 @ .360	56 @ 7.5	3.94 @ .473
40	2.81	61 @ 3.5	4.29 @ .221	62 @ 4.5	4.36 @ .341	74 @ 6.4	5.20 @ .403	74 @ 8.5	5.20 @ .536
50	3.51	77 @ 3.8	5.41 @ .240	77 @ 5.0	5.41 @ .379	91 @ 7.0	6.40 @ .442	87 @ 9.6	6.12 @ .606
60	4.21	90 @ 4.2	6.33 @ .259	92 @ 5.4	6.47 @ .409	107 @ 7.7	7.52 @ .486	104 @ 10.6	7.31 @ .669
70	4.92	106 @ 4.5	7.45 @ .284	106 @ 5.8	7.45 @ .439	124 @ 8.2	8.72 @ .517	120 @ 11.3	8.44 @ .713
80	5.62	120 @ 4.6	8.44 @ .290	120 @ 6.1	8.44 @ .462	141 @ 8.7	9.91 @ .549	138 @ 12.0	9.70 @ .757
90	6.32	134 @ 4.9	9.42 @ .309	135 @ 6.5	9.49 @ .492	158 @ 9.2	11.11 @ .580	155 @ 12.7	10.90 @ .801
100	7.03	149 @ 5.1	10.48 @ .322	150 @ 6.7	10.55 @ .508	173 @ 9.7	12.16 @ .612	171 @ 13.3	12.02 @ .839
110	7.73	162 @ 5.3	11.40 @ .334	164 @ 7.1	11.53 @ .538	188 @ 10.1	13.22 @ .637	188 @ 13.9	13.22 @ .877
120	8.44	178 @ 5.6	12.51 @ .353	179 @ 7.5	12.58 @ .568	205 @ 10.5	14.41 @ .662	205 @ 14.5	14.41 @ .915
130	9.14	192 @ 5.8	13.50 @ .366	192 @ 7.7	13.50 @ .583	222 @ 10.9	15.61 @ .688	221 @ 14.9	15.54 @ .940
140	9.84	207 @ 6.0	14.55 @ .379	208 @ 8.1	14.62 @ .614	238 @ 11.3	16.73 @ .713	238 @ 15.6	16.73 @ .984
150	10.55	222 @ 6.2	15.61 @ .391	223 @ 8.4	15.68 @ .636	255 @ 11.7	17.93 @ .738	254 @ 16.0	17.86 @ 1.01
160	11.25	236 @ 6.4	16.59 @ .404	237 @ 8.6	16.66 @ .652	270 @ 12.0	18.98 @ .757	270 @ 16.5	18.98 @ 1.04

Maximum Chlorine Feed Rate — 10 PPD (200 Grams/Hr.) See Note.

NOZZLE		No. 13A		No. 14A		No. 15A		No. 16A	
EJECTOR BACKPRESSURE		REQUIRED Ejector Supply Pressure and Water Flow Rate		REQUIRED Ejector Supply Pressure and Water Flow Rate		REQUIRED Ejector Supply Pressure and Water Flow Rate		REQUIRED Ejector Supply Pressure and Water Flow Rate	
PSIG	kg/cm ²	PSIG @ GPM	kg/cm ² @ l/sec.	PSIG @ GPM	kg/cm ² @ l/sec.	PSIG @ GPM	kg/cm ² @ l/sec.	PSIG @ GPM	kg/cm ² @ l/sec.
0	0	10 @ 1.2	.703 @ .076	6 @ 1.7	.422 @ .107	4 @ 2.1	0.28 @ .132	5 @ 2.8	.352 @ .177
10	0.70	26 @ 2.3	1.83 @ .139	21 @ 2.7	1.48 @ .170	24 @ 3.8	1.69 @ .240	20 @ 4.9	1.41 @ .309
20	1.40	39 @ 2.7	2.74 @ .170	32 @ 3.3	2.53 @ .208	40 @ 4.8	2.81 @ .303	39 @ 6.7	2.74 @ .423
30	2.10	50 @ 3.1	3.52 @ .196	52 @ 4.0	3.94 @ .252	58 @ 5.7	4.08 @ .360	55 @ 7.8	3.87 @ .492
40	2.81	62 @ 3.5	4.36 @ .221	62 @ 4.5	4.78 @ .284	74 @ 6.3	5.20 @ .397	74 @ 9.0	5.20 @ .568
50	3.51	76 @ 3.8	5.34 @ .240	78 @ 5.0	5.91 @ .315	91 @ 7.0	6.40 @ .442	87 @ 10.2	6.12 @ .644
60	4.21	90 @ 4.2	6.33 @ .265	92 @ 5.4	7.03 @ .341	108 @ 7.6	7.59 @ .480	103 @ 11.2	7.24 @ .707
70	4.92	104 @ 4.5	7.31 @ .284	108 @ 5.8	8.16 @ .366	124 @ 8.2	8.72 @ .517	120 @ 11.8	8.44 @ .744
80	5.62	118 @ 4.8	8.30 @ .303	121 @ 6.1	9.28 @ .385	140 @ 8.7	9.84 @ .549	138 @ 12.6	9.70 @ .795
90	6.32	132 @ 5.1	9.28 @ .322	136 @ 6.4	10.48 @ .404	157 @ 9.2	11.04 @ .580	155 @ 13.2	10.90 @ .833
100	7.03	147 @ 5.3	10.34 @ .334	151 @ 6.8	11.39 @ .429	174 @ 9.7	12.23 @ .612	172 @ 13.8	12.02 @ .871
110	7.73	161 @ 5.5	11.32 @ .347	167 @ 7.1	12.51 @ .448	189 @ 10.1	13.29 @ .637	188 @ 14.5	13.22 @ .915
120	8.44	175 @ 6.0	12.30 @ .379	180 @ 7.4	13.57 @ .467	206 @ 10.5	14.48 @ .662	205 @ 15.0	14.41 @ .946
130	9.14	188 @ 6.2	13.22 @ .391	195 @ 7.7	14.69 @ .486	222 @ 10.8	15.61 @ .681	222 @ 15.6	15.61 @ .984
140	9.84	204 @ 6.4	14.34 @ .404	209 @ 8.0	15.82 @ .505	238 @ 11.3	16.73 @ .715	239 @ 16.2	16.80 @ 1.02
150	10.55	217 @ 6.6	15.26 @ .416	224 @ 8.3	16.87 @ .523	254 @ 11.6	17.86 @ .732	256 @ 16.7	18.00 @ 1.05
160	11.25	230 @ 6.8	16.17 @ .429	238 @ 8.6	18.00 @ .543	269 @ 12.0	18.91 @ .757	272 @ 17.2	19.12 @ 1.09

Maximum Chlorine Feed Rate — 25 PPD (500 Grams/Hr.) See Note.

NOZZLE		No. 13A		No. 14A		No. 15A		No. 16A	
EJECTOR BACKPRESSURE		REQUIRED Ejector Supply Pressure and Water Flow Rate		REQUIRED Ejector Supply Pressure and Water Flow Rate		REQUIRED Ejector Supply Pressure and Water Flow Rate		REQUIRED Ejector Supply Pressure and Water Flow Rate	
PSIG	kg/cm ²	PSIG @ GPM	kg/cm ² @ l/sec.	PSIG @ GPM	kg/cm ² @ l/sec.	PSIG @ GPM	kg/cm ² @ l/sec.	PSIG @ GPM	kg/cm ² @ l/sec.
0	0	15 @ 1.6	1.05 @ .101	11 @ 2.2	.773 @ .139	6 @ 2.2	0.42 @ .139	7 @ 2.7	.492 @ .170
10	0.70	38 @ 2.7	2.67 @ .170	28 @ 3.0	1.97 @ .221	24 @ 3.8	1.69 @ .240	23 @ 5.0	1.62 @ .315
20	1.40	60 @ 3.3	4.22 @ .208	42 @ 3.7	2.95 @ .271	36 @ 4.6	2.53 @ .290	38 @ 6.1	2.67 @ .385
30	2.10	76 @ 3.6	5.34 @ .227	55 @ 4.2	3.87 @ .303	53 @ 5.4	3.73 @ .341	55 @ 7.5	3.87 @ .473
40	2.81	83 @ 4.0	6.19 @ .252	66 @ 4.9	4.64 @ .328	69 @ 6.1	4.85 @ .385	73 @ 8.6	5.13 @ .543
50	3.51	100 @ 4.4	7.03 @ .265	78 @ 5.2	5.48 @ .353	87 @ 6.8	6.12 @ .429	90 @ 9.5	6.33 @ .599
60	4.21	103 @ 4.4	7.80 @ .278	93 @ 5.7	6.54 @ .379	103 @ 7.4	7.24 @ .467	105 @ 10.3	7.38 @ .650
70	4.92	114 @ 4.6	8.44 @ .290	108 @ 6.1	7.59 @ .404	118 @ 8.0	8.30 @ .505	123 @ 11.2	8.65 @ .707
80	5.62	125 @ 4.8	9.35 @ .303	122 @ 6.5	8.58 @ .423	135 @ 8.5	9.49 @ .536	139 @ 12.0	9.77 @ .757
90	6.32	139 @ 5.4	10.05 @ .328	138 @ 6.8	9.70 @ .454	153 @ 9.0	10.76 @ .568	156 @ 12.6	10.97 @ .795
100	7.03	154 @ 5.6	10.83 @ .353	152 @ 7.3	10.69 @ .473	168 @ 9.5	11.81 @ .599	172 @ 13.2	12.09 @ .833
110	7.73	167 @ 5.8	11.74 @ .366	168 @ 7.7	11.81 @ .498	184 @ 9.8	12.94 @ .618	189 @ 13.9	13.29 @ .877
120	8.44	179 @ 6.1	12.58 @ .385	182 @ 7.9	12.80 @ .524	201 @ 10.3	14.13 @ .650	206 @ 14.4	14.48 @ .908
130	9.14	193 @ 6.3	13.57 @ .397	200 @ 8.3	14.06 @ .543	217 @ 10.8	15.26 @ .681	223 @ 15.0	15.68 @ .946
140	9.84	207 @ 6.5	14.55 @ .410	209 @ 8.5	14.69 @ .562	233 @ 11.2	16.38 @ .707	240 @ 15.6	16.87 @ .984
150	10.55	222 @ 6.7	15.61 @ .423	224 @ 8.8	15.75 @ .580	250 @ 11.5	17.58 @ .726	257 @ 16.1	18.07 @ 1.02
160	11.25	236 @ 6.9	16.59 @ .435	239 @ 9.1	16.80 @ .599	266 @ 11.8	18.70 @ .744	273 @ 16.6	19.19 @ 1.05

*Standard Nozzle Supplied with Chlorinator for Indicated Maximum Feed Rate. NOTE: GPM is U.S. Gallons. Metric is liters per sec. (l/sec.)

Maximum Chlorine Feed Rate — 50 PPD (900 Grams/Hr.) See Note.

NOZZLE		No. 13A		No. 14A		No. 15A		No. 16A	
EJECTOR BACKPRESSURE		REQUIRED Ejector Supply Pressure and Water Flow Rate		REQUIRED Ejector Supply Pressure and Water Flow Rate		REQUIRED Ejector Supply Pressure and Water Flow Rate		REQUIRED Ejector Supply Pressure and Water Flow Rate	
PSIG	kg/cm ²	PSIG @ GPM	kg/cm ² @ l/sec.	PSIG @ GPM	kg/cm ² @ l/sec.	PSIG @ GPM	kg/cm ² @ l/sec.	PSIG @ GPM	kg/cm ² @ l/sec.
0	0	29 @ 2.4	2.04 @ .151	10 @ 3.1	1.69 @ .196	13 @ 3.1	0.84 @ .196	13 @ 3.7	.914 @ .233
10	0.70	65 @ 3.5	4.57 @ .221	45 @ 4.2	3.16 @ .265	39 @ 4.8	2.74 @ .303	31 @ 5.8	2.18 @ .366
20	1.40	95 @ 4.1	6.68 @ .259	63 @ 4.8	4.43 @ .303	53 @ 5.5	3.73 @ .347	47 @ 6.9	3.30 @ .435
30	2.10	111 @ 4.6	7.80 @ .290	80 @ 5.4	5.62 @ .341	68 @ 6.1	4.79 @ .385	59 @ 7.7	4.15 @ .486
40	2.81	125 @ 4.9	8.79 @ .309	94 @ 5.8	6.61 @ .366	82 @ 6.7	5.77 @ .423	73 @ 8.6	5.13 @ .543
50	3.51	138 @ 5.5	9.70 @ .353	108 @ 6.2	7.59 @ .391	95 @ 7.4	6.68 @ .467	89 @ 9.6	6.26 @ .606
60	4.21	150 @ 5.7	10.55 @ .360	120 @ 6.5	8.44 @ .410	108 @ 7.9	7.59 @ .498	106 @ 10.4	7.45 @ .656
70	4.92	161 @ 5.9	11.32 @ .372	132 @ 6.8	9.28 @ .429	125 @ 8.4	8.79 @ .530	123 @ 11.2	8.65 @ .707
80	5.62	172 @ 6.1	12.09 @ .385	143 @ 7.2	10.05 @ .454	142 @ 8.9	9.98 @ .562	140 @ 12.1	9.84 @ .763
90	6.32	185 @ 6.2	13.00 @ .391	155 @ 7.4	10.90 @ .467	158 @ 9.4	11.11 @ .593	158 @ 12.7	11.11 @ .801
100	7.03	192 @ 6.4	13.50 @ .404	166 @ 7.6	11.67 @ .479	174 @ 9.8	12.23 @ .618	174 @ 13.3	12.23 @ .839
110	7.73	205 @ 6.5	14.41 @ .410	176 @ 7.9	12.37 @ .498	190 @ 10.3	13.36 @ .650	191 @ 13.9	13.43 @ .877
120	8.44	215 @ 6.6	15.12 @ .416	190 @ 8.1	13.36 @ .511	206 @ 10.7	14.48 @ .675	207 @ 14.6	14.55 @ .921
130	9.14	224 @ 6.8	15.75 @ .429	203 @ 8.4	14.27 @ .536	223 @ 11.2	15.68 @ .707	224 @ 15.1	15.75 @ .953
140	9.84	236 @ 7.0	16.59 @ .442	214 @ 8.6	15.05 @ .543	240 @ 11.5	16.87 @ .726	241 @ 15.6	16.94 @ .984
150	10.55	248 @ 7.1	17.44 @ .448	228 @ 8.8	16.03 @ .568	255 @ 11.7	17.93 @ .738	257 @ 16.1	18.07 @ 1.02
160	11.25	260 @ 7.2	18.28 @ .461	241 @ 9.2	16.94 @ .593	271 @ 12.2	19.05 @ .770	275 @ 16.6	19.33 @ 1.05

Maximum Chlorine Feed Rate — 100 PPD (2000 Grams/Hr.) See Note.

NOZZLE		No. 13A		No. 14A		No. 15A		No. 16A	
EJECTOR BACKPRESSURE		REQUIRED Ejector Supply Pressure and Water Flow Rate		REQUIRED Ejector Supply Pressure and Water Flow Rate		REQUIRED Ejector Supply Pressure and Water Flow Rate		REQUIRED Ejector Supply Pressure and Water Flow Rate	
PSIG	kg/cm ²	PSIG @ GPM	kg/cm ² @ l/sec.	PSIG @ GPM	kg/cm ² @ l/sec.	PSIG @ GPM	kg/cm ² @ l/sec.	PSIG @ GPM	kg/cm ² @ l/sec.
0	0	55 @ 3.6	3.87 @ .227	48 @ 4.2	3.37 @ .265	31 @ 4.3	2.18 @ .271	22 @ 5.2	1.55 @ .328
10	0.70	102 @ 4.4	7.17 @ .278	76 @ 5.3	5.34 @ .334	58 @ 5.6	4.08 @ .353	49 @ 7.5	3.45 @ .473
20	1.40	136 @ 5.0	10.55 @ .315	100 @ 6.0	7.03 @ .379	75 @ 6.4	5.27 @ .404	69 @ 8.8	4.85 @ .555
30	2.10	162 @ 5.4	12.73 @ .341	118 @ 6.4	8.30 @ .404	92 @ 7.1	6.47 @ .448	85 @ 9.7	5.98 @ .612
40	2.81	181 @ 5.6	14.48 @ .353	136 @ 6.8	9.56 @ .429	108 @ 7.7	7.59 @ .486	101 @ 10.5	7.10 @ .662
50	3.51	198 @ 5.9	15.90 @ .366	153 @ 7.3	10.76 @ .461	122 @ 8.1	8.58 @ .511	116 @ 11.2	8.16 @ .707
60	4.21	216 @ 6.1	17.15 @ .385	168 @ 7.7	11.81 @ .486	136 @ 8.6	9.56 @ .543	128 @ 11.8	9.00 @ .744
70	4.92	230 @ 6.4	18.14 @ .404	185 @ 8.0	13.01 @ .505	151 @ 8.9	10.62 @ .562	139 @ 12.3	9.77 @ .776
80	5.62	244 @ 6.6	19.76 @ .416	201 @ 8.3	14.13 @ .524	165 @ 9.3	11.60 @ .587	150 @ 12.8	10.55 @ .808
90	6.32	258 @ 6.7	20.67 @ .429	213 @ 8.5	14.98 @ .536	180 @ 9.8	12.66 @ .618	164 @ 13.4	11.53 @ .845
100	7.03	269 @ 7.0	21.58 @ .435	222 @ 8.8	15.61 @ .555	193 @ 10.1	13.57 @ .637	180 @ 14.0	12.66 @ .883
110	7.73	—	—	232 @ 9.0	16.31 @ .568	207 @ 10.4	14.55 @ .656	195 @ 14.5	13.71 @ .915
120	8.44	—	—	247 @ 9.2	17.37 @ .580	221 @ 10.8	15.54 @ .681	212 @ 15.0	14.91 @ .946
130	9.14	—	—	260 @ 9.5	18.28 @ .599	236 @ 11.2	16.59 @ .706	227 @ 15.5	15.96 @ .978
140	9.84	—	—	273 @ 9.6	19.19 @ .618	250 @ 11.5	17.58 @ .726	245 @ 16.2	17.23 @ 1.02
150	10.55	—	—	284 @ 9.8	19.97 @ .637	265 @ 11.8	18.63 @ .744	261 @ 16.7	18.35 @ 1.05
160	11.25	—	—	295 @ 10.0	20.74 @ .662	281 @ 12.2	19.76 @ .770	278 @ 17.2	19.55 @ 1.09

*Standard Nozzle Supplied with Chlorinator for Indicated Maximum Feed Rate. NOTE: GPM is U.S. Gallons. Metric is liters per sec. (l/sec.)

Application Bulletin No. 1009**REGAL Series 2000 Gas Chlorinators****1000 LBS/24 HRS. (20kg/hr)**

EJECTOR BACKPRESSURE		REQUIRED Ejector Supply Pressure & Water Flow Rate			
		A-2920 EJECTOR - 0.563" (STD)		A-2922 EJECTOR - 0.750"	
PSIG	kg/cm ²	PSIG @ GPM	kg/cm ² @ 1/sec	PSIG @ GPM	kg/cm ² @ 1/sec
0	0.00	15 @ 34.5	1.05 @ 2.18	8 @ 46.0	0.57 @ 2.90
10	0.70	35 @ 43.7	2.43 @ 2.76	16 @ 65.6	1.13 @ 4.13
20	1.41	58 @ 52.9	4.04 @ 3.34	30 @ 84.0	2.10 @ 5.30
30	2.11	85 @ 62.1	5.98 @ 3.92	48 @ 98.9	3.40 @ 6.24
40	2.81	115 @ 71.3	8.08 @ 4.50	67 @ 112.7	4.69 @ 7.11
50	3.52	147 @ 82.8	10.35 @ 5.22	87 @ 126.5	6.14 @ 7.98
60	4.22	—	—	108 @ 136.9	7.60 @ 8.63
70	4.92	—	—	129 @ 149.5	9.05 @ 9.43

2000 LBS/24 HRS. (40kg/hr)

EJECTOR BACKPRESSURE		REQUIRED Ejector Supply Pressure & Water Flow Rate			
		A-2922 EJECTOR - 0.750" (STD)		A-2920 EJECTOR - 0.563"	
PSIG	kg/cm ²	PSIG @ GPM	kg/cm ² @ 1/sec	PSIG @ GPM	kg/cm ² @ 1/sec
0	0.00	41 @ 104.7	2.91 @ 6.60	41 @ 48.3	2.91 @ 3.05
10	0.70	48 @ 108.1	3.40 @ 6.82	78 @ 62.1	5.50 @ 3.92
20	1.41	58 @ 110.4	4.04 @ 6.96	102 @ 71.3	7.20 @ 4.50
30	2.11	68 @ 117.3	4.77 @ 7.40	124 @ 77.1	8.73 @ 4.86
40	2.81	81 @ 126.5	5.66 @ 7.98	146 @ 81.7	10.27 @ 5.15
50	3.52	97 @ 134.6	6.79 @ 8.49	—	—
60	4.22	113 @ 141.5	7.92 @ 8.92	—	—
70	4.92	130 @ 154.1	9.14 @ 9.72	—	—



1044 SE Dixie Cutoff Road, Stuart, Florida 34994 USA

Phone: (772) 288-4854 • Fax: (772) 287-3238 • www.regalchlorinators.com • Email: regal@regalchlorinators.com

REGAL GAS CHLORINATORS: PURE WATER. PURE AND SIMPLE.

Copyright 2014 Chlorinators Incorporated

Printed in U.S.A.
Pub. No. 0614-1

